



## WHEEL LOADER | 406/407/409

Max. Engine power: 36.4kW (49hp) / 48kW (64hp) / 54.5kW (74hp) Max. Operating weight: 5020kg / 5210kg / 6031kg



## PRODUCTIVE PERFORMANCE.

THE JCB 406, 407 AND 409 ARE HIGHLY PRODUCTIVE WHEEL LOADERS WITH OPTIMAL POWER-TO-WEIGHT RATIO, MAKING THEM PERFECT TOOL CARRIERS. BOTH LARGER MACHINES ARE TIER 4 FINAL/STAGE IV-COMPLIANT USING JUST A DIESEL OXIDATION CATALYST (DOC). THEY'RE ALSO MORE FRUGAL THAN OUTGOING TIER 3 MODELS.

Hydrostatic drive makes these models very easy to operate even for the inexperienced. That means there's less risk of overpowering the machine at a cost to fuel economy.



### JCB Diesel by Kohler.

**1** JCB has worked in close collaboration with Kohler to produce the ultimate compact wheel loader engine. No engine power is wasted on a DPF and, with peak power and torque produced at low revs, you get good fuel economy too. Our design also makes dimensions compact for small turning circles.

The 406 has an easy-maintenance mechanical JCB Diesel engine by Kohler offering potent performance.

**2** Our 407 and 409 machines are equipped with a variable speed engine crank-driven cooling fan that maintains optimum fan speed for all requirements without using any excess engine power.

**3** The JCB 407 and 409 have a high speed option – this provides a top speed of 35 km/h (407) and 40 km/h (409).



**1**



**2**



**3**

With our High Flow option, you get an extra 30 litres of hydraulic capacity for an enhanced flow rate.

### Moving with the times.

4 JCB's articulated steering boasts an easy-to-use built-in sideshift – ideal for pallet handling and changing attachments.

5 So that you can tailor your wheel loader to any application, we offer several axle options. Open diffs are ideal for hard ground, and limited slip diffs excel on soft muddy terrain. Our 100% switchable front axle diff lock on the 407 and 409, meanwhile, provides ultimate traction on muddy terrain and creates no shear forces, so won't damage the ground when it's not in use. It can also be engaged on the move and under load.

6 Power from the driveline is transferred to the ground very efficiently through an innovative chassis, with perfect harmony between all components. This makes our machines the best possible wheeled loader solution.

### Versatility by the bucketload.

7 Equip your wheel loader with our new towing option and you'll get a hitch with rear electrics and hydraulics, allowing you to trailer loads of up to 3.5 tonnes or carry rear attachments like salt spreaders.

8 By splitting power between the transmission and the hydraulics, our inching pedal allows precise, efficient, stepless load handling.

Our wheel loaders are even more versatile when you use both front and rear attachments; you could, for example, combine a snow plough and rear grit spreader.



4



6



5



7



8

## QUALITY, RELIABILITY AND DURABILITY.

AT JCB, WE UNDERSTAND THAT A WHEEL LOADER IS A KEY PART OF ANY ON-SITE PROCESS. THAT'S WHY THE 406, 407 AND 409 ARE BUILT ON A FOUNDATION OF QUALITY AND RELIABILITY, ENSURING THAT THEY'LL ALWAYS BE A KEY PART OF YOUR WORKING PROCESS.

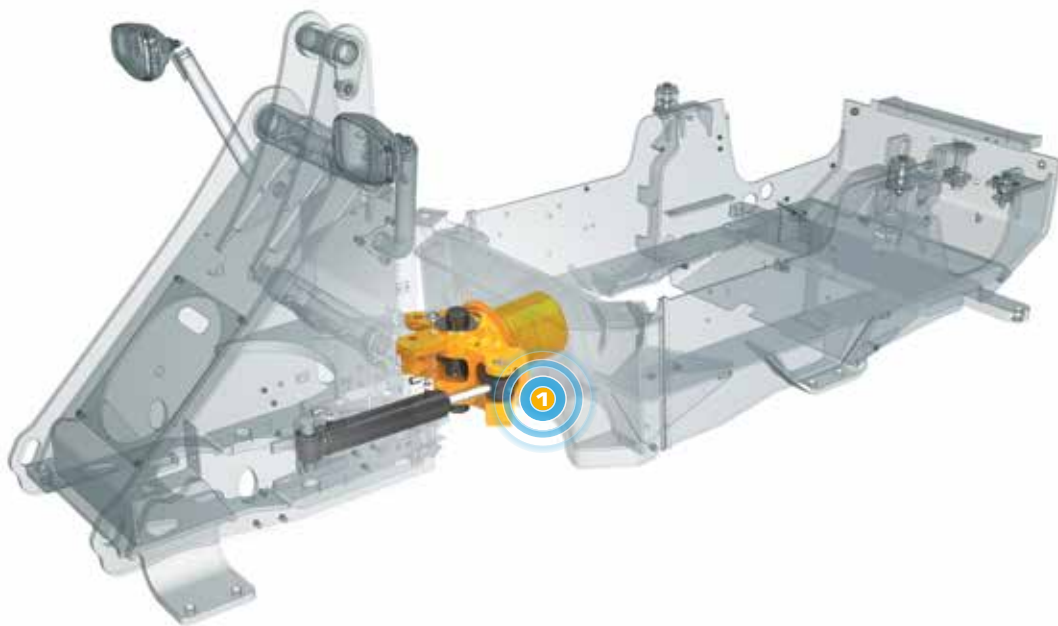

We've used only the very finest engine, driveline and axle components on the 406, 407 and 409, from suppliers like DANA and Bosch.



### Built to last.

- 1 We understand how tough materials handling can be, so our machines are developed to be highly durable. A case in point is our heavy-duty centre joint, which oscillates through  $\pm 10^\circ$ .
- 2 These machines benefit from a strong chassis and the best possible weight distribution; this allows for the best possible absorption of external forces.



### Quality design.

- 3 The JCB 406, 407 and 409 all have rear lights that are recessed within the solid counterweight casting for good impact protection.
- 4 Hydraulic hoses are always well protected; they're neatly routed, properly clamped, and positioned well away from potential pinching spots.
- 5 We use state-of-the-art manufacturing processes like robot machining, precision paint technology and innovative assembly techniques to achieve the very highest levels of quality.
- 6 Precision machining provides high tolerances and accurate location of pins and bushes.
- 7 Finite element analysis and rig testing ensure superior structural strength and durability. Cold cell testing guarantees starting performance at temperatures as low as -20°C.



## COMFORT AND EASE OF USE.

JCB COMPACT WHEEL LOADERS LIKE THE 406, 407 AND 409 ARE DESIGNED TO MAKE WORK MORE STRAIGHTFORWARD. THEY'RE EASY TO ACCESS, INTUITIVE TO OPERATE, AND THEY'RE OPERATED FROM THE CENTRE OF THE MACHINE FOR SUPERB VISIBILITY. AFTER ALL, A COMFORTABLE, CONFIDENT OPERATOR IS A MORE PRODUCTIVE ONE.

In-cab noise levels on these machines are lower than outgoing models.

### A comfortable operator.

**1** The JCB 406, 407 and 409 all benefit from a comfortable and spacious cab. The operating position is designed for optimum all-round visibility, unhindered by components like silencers.

**2** Our tilting telescopic steering column is easy to adjust for an ergonomic driving position.

**3** All the instruments needed to operate a JCB wheel loader are within easy reach of the seat, so there's no need to hunt around for information whilst working.

**4** With a fully opening right-hand window operators can enjoy increased ventilation whilst still being protected from dust.



1



2



3



4

### In complete control.

5 A stylish, modern central dash display on the 407 and 409 combines analogue dials and a colour LCD screen – this can display machine health details, service requirements, operating information and more.

6 These compact wheel loaders are equipped with an ergonomically designed joystick control system for comfortable and intuitive operation.



## SERVICEABILITY.

A WHEELED LOADING SHOVEL NEEDS TO SPEND AS MUCH TIME AS POSSIBLE HARD AT WORK. THAT'S WHY THE JCB 406, 407 AND 409 BENEFIT FROM INNOVATIVE DESIGN AND QUALITY COMPONENTS, ALLOWING THEM TO OFFER MAXIMUM UPTIME WITH LONG SERVICE INTERVALS.

### Access all areas.

**1** Our large single piece bonnet ensures quick and convenient access to the engine bay and cooling pack areas of your wheel loader. All daily check points are easily accessed under the bonnet.

**2** Operators and managers alike can access vital information like machine running times, fuel consumption and error alerts – it's all available at the touch of a button on the in-cab display or if needed via JCB's LiveLink telematics system.

**3** The 407 and 409 have a cyclonic pre-filter which maximises air filtration and extends filter element service intervals significantly. On the 406, there's a traditional cylinder-type air filter that's perfectly sized for the smaller engine, ensuring robust and cost-effective performance.

The new Kohler engine does not use a Diesel Particulate Filter (DPF) or SCR, requiring costly Diesel Exhaust Fluid (DEF) level maintenance or heat-resistant lube oils. Thus reducing service and running costs.



**4** Your local JCB dealer will be able to supply all parts for your 406, 407 or 409, even JCB Diesel by Kohler engine components. All three machines also share parts with other JCB machinery, which makes everything even more readily available.





## SAFETY AND SECURITY.

BECAUSE SAFETY AND SECURITY ARE PARAMOUNT ON ANY SITE, THE JCB 406, 407, AND 409 ARE DESIGNED TO PROTECT THEIR OPERATORS, THEMSELVES, AND ANY BYSTANDERS AT ALL TIMES. GREAT VISIBILITY, ANTI-THEFT FEATURES AND NON-SLIP SURFACES ARE JUST THE START.

### Safety first.

The 406, 407 and 409 can be equipped with a new immobiliser option, which can help prevent thefts from your fleet.

1 With no exhaust after treatment, our JCB Diesel by Kohler engines are extremely compact, so there's no compromise to visibility. The sloping rear bonnet provides an unimpeded view, with the exhaust silencer and air intake filter both packaged out of sight.

2 We've fitted an in-cab electronic 2-stage quickhitch isolation system to prevent uncontrolled release of attachments.

3 Access steps are inclined and complemented by well positioned handles so that operators have three points of contact whenever they're entering or exiting the cab.



## LIVELINK, WORK SMARTER.

**LIVELINK IS AN INNOVATIVE SOFTWARE SYSTEM THAT LETS YOU MANAGE JCB MACHINES REMOTELY – ONLINE, BY EMAIL OR BY MOBILE PHONE. ACCESS EVERYTHING FROM MACHINE ALERTS TO FUEL REPORTS AND HISTORY INFORMATION, WITH ALL DATA STORED AT A SECURE CENTRE.**

### Productivity and cost benefits

By providing information like idle time monitoring and machine fuel consumption, JCB LiveLink helps reduce your fuel usage, saving money and improving productivity. Machine location information can help improve efficiency and perhaps even reduce insurance costs.



### Maintenance benefits

Manage machine maintenance easily – accurate hours monitoring and service alerts improve maintenance planning, while real-time location data helps you manage your fleet. Critical machine alerts and maintenance history records are also available.



### Security benefits

LiveLink's real-time geofencing alerts tell you when machines move out of predetermined zones, and real-time curfew alerts inform you of unauthorised usage. Further benefits include real-time location information.



## VALUE ADDED.

JCB'S WORLDWIDE CUSTOMER SUPPORT IS FIRST CLASS. WHATEVER YOU NEED AND WHEREVER YOU ARE, WE'LL BE AVAILABLE QUICKLY AND EFFICIENTLY TO HELP MAKE SURE YOUR MACHINERY IS PERFORMING TO ITS FULL POTENTIAL.



1

1 Our Technical Support Service provides instant access to factory expertise, day or night, while our Finance and Insurance teams are always on hand to provide fast, flexible, competitive quotes.

2 The global network of JCB Parts Centres is another model of efficiency; with 16 regional bases, we can deliver around 95% of all parts anywhere in the world within 24 hours. Our genuine JCB parts are designed to work in perfect harmony with your machine for optimum performance and productivity.



2

3 JCB Assetcare offers comprehensive extended warranties and service agreements, as well as service-only or repair and maintenance contracts. Irrespective of what you opt for, our Maintenance teams around the world charge competitive labour rates, and offer non-obligation quotations as well as fast, efficient insurance repair work.



3

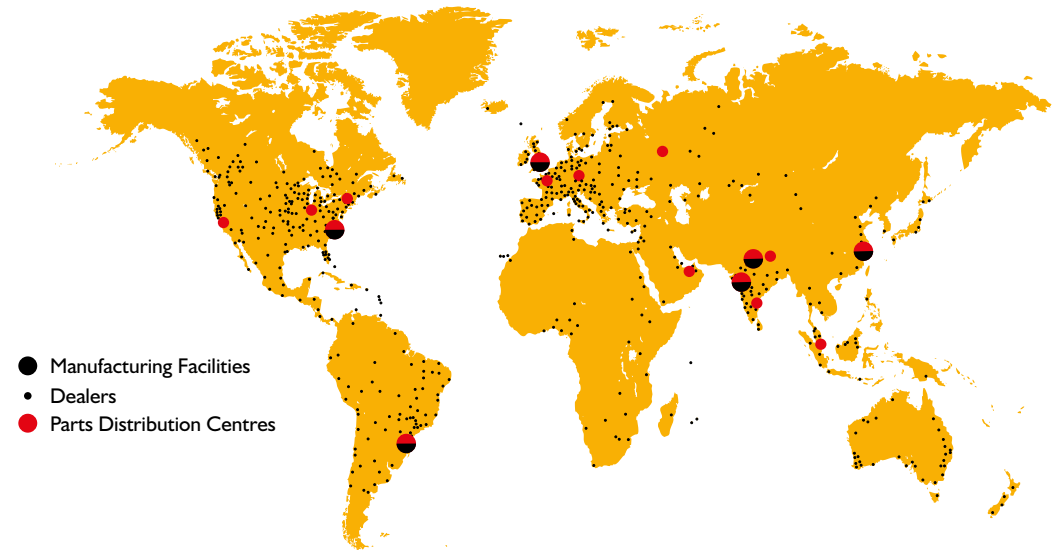

- Manufacturing Facilities
- Dealers
- Parts Distribution Centres

Note: JCB LIVELINK and JCB ASSETCARE may not be available in your region, so please check with your local dealer.

STATIC DIMENSIONS

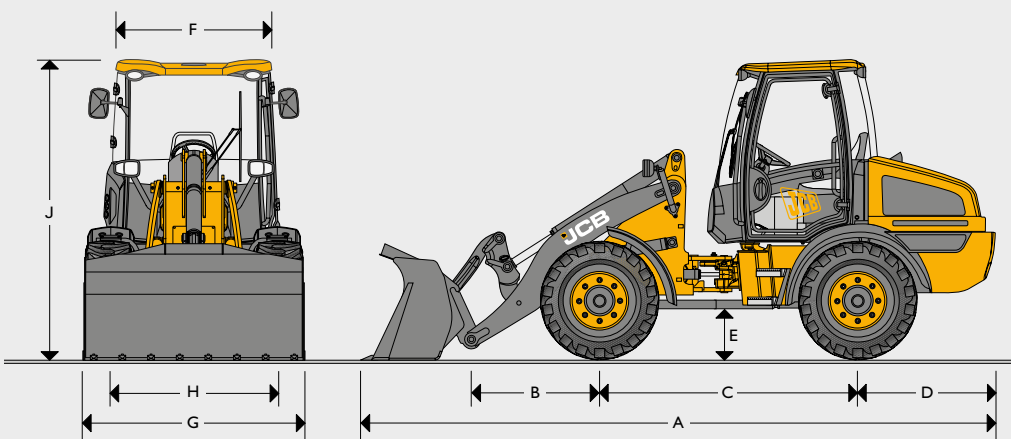

		406	407	409	
A	Overall length	mm	5133	5133	5465
B	Axle to pivot pin	mm	906	906	1130
C	Wheelbase	mm	2100	2100	2205
D	Axle to counterweight face	mm	1268	1268	1295
E	Ground clearance	mm	313	313	472
F	Width over cab	mm	1468	1468	1468
G	Width over tyres	mm	1727	1727	1898
H	Wheel track	mm	1390	1390	1490
J	Height over cab	mm	2500	2500	2643
	Front axle weight	kg	1475	1395	1850
	Rear axle weight	kg	3398	3668	4076
	Total weight	kg	4873	5063	5926
	Inside turn radius	mm	2010	2010	2079
	Max. turn radius over shovel	mm	4160	4160	4432
	Articulation angle	deg	±40°	±40°	±40°
	Max. radius over tyre	mm	3800	3800	3979
	Max. width across tyres	mm	1761	1864	1900

406/407 data based on machine equipped with pin mounted 0.8m³ bucket with toe plates and Camso SLR4 12.5-18 tyres.

409 data based on machine equipped with pin mounted 1.0 m³ bucket with toe plates and Mitas MPT-04 tyres.

ENGINE

		406	407	409
Type		4 stroke, Mechanical	4 stroke, Electronic Common Rail	4 stroke, Electronic Common Rail
Model		JCB Diesel by Kohler - KDI 2504 M	JCB Diesel by Kohler - KDI 2504 TCR	JCB Diesel by Kohler KDI 2504 TCR
Capacity	litres	2.482	2.482	2.482
Aspiration		Normally aspirated	Turbocharged	Turbocharged
Cylinders		4	4	4
Max gross power to SAE J1995/ISO 14396	kW (hp)	36.4 (49) @ 2600rpm	48 (64) @ 2200rpm	54.5 (74) @ 2200rpm
Max torque	Nm @ 1500rpm	170	300	300
Emissions		Stage IIIA	Stage IIIB & T4F	Stage IIIB & T4F

TRANSMISSION

		406	407	409
Type		Hydrostatic	Hydrostatic	Hydrostatic
Model		Rexroth A6VM – 2 speed	Rexroth A6VM – 2 speed	Rexroth A6VM – 2 speed
Model (40kph options)		n/a	Rexroth A6VM – 3 speed	Rexroth A6VM – 3 speed
Low range	kph	6	6	6
High range	kph	20	18	20
High speed (optional)	kph	n/a	35	40

AXLES

		406	407	409
Type		Straight beam	Straight beam	Straight beam
Make and model		Dana III	Dana III	Dana III
Chassis angle oscillation	degrees	± 10	± 10	± 10

STEERING

Hydraulic power steering system emergency steering.

**LOADER DIMENSIONS**

Model (assumes machine is fitted with Camso SLR4 12.5-18 tyres) (406 and 407 only)		406					407					409				
		General purpose	General purpose	Light duty	Light duty	6 in 1 clam shovel	General purpose	General purpose	Light duty	Light duty	6 in 1 clam shovel	General purpose	General purpose	Light duty	Light duty	6 in 1 clam shovel
Bucket type		Teeth or toeplate		Toeplate		Teeth or toeplate	Teeth or toeplate		Toeplate		Teeth or toeplate	Teeth or toeplate		Toeplate		Teeth or toeplate
Bucket capacity (SAE heaped)	m <sup>3</sup>	0.8	1	1.2	1.4	0.75	0.8	1	1.2	1.4	0.75	1	1.2	1.4	1.6	0.9
Bucket width	mm	1900	1900	1900	1900	1900	1900	1900	1900	1900	1900	1950	1950	2100	2200	1950
Bucket weight	kg	287	322	353	384	435	287	322	353	384	435	332	358	399	434	436
Max. material density	kg/m <sup>3</sup>	2050	1620	1320	1120	2100	2050	1620	1320	1120	2100	1957	1602	1346	1157	2090
Tipping load straight	kg	4225	4148	4055	4014	4033	4323	4245	4149	4108	4127	4583	4503	4415	4337	3830
Tipping load full turn	kg	3250	3191	3120	3088	3102	3326	3265	3193	3160	3174	3648	3584	3513	3452	3507
Payload	kg	1625	1595	1560	1544	1551	1663	1633	1596	1580	1587	1824	1792	1756	1725	1754
Max. breakout force	kN	41.9	36.5	32.2	29.7	41.9	41.9	36.5	32.2	29.7	41.9	53.8	46.6	43.1	41.6	50.8
M Dump angle maximum	degrees	45	45	45	45	45	45	45	45	45	45	45	45	45	45	45
N Roll back angle full height	degrees	56	56	56	56	56	56	56	56	56	56	63.6	63.6	63.6	63.6	63.6
O Roll back at carry	degrees	54	54	54	54	54	54	54	54	54	54	53.1	53.1	53.1	53.1	53.1
P Roll back at ground level	degrees	42	42	42	42	42	42	42	42	42	42	41	41	41	41	41
Q Load over height	mm	2991	2991	2991	2991	2991	2991	2991	2991	2991	2991	3189	3189	3189	3189	3189
R Dump height (45 deg dump)	mm	2489	2418	2348	2295	2489	2489	2418	2348	2295	2489	2619	2552	2500	2446	2609
S Dig depth	mm	105	105	105	105	106	105	105	105	105	106	60	60	60	60	60
T Reach at dump height	mm	764	835	905	958.5	764	764	835	905	958.5	764	523	599	652	705	523
Reach maximum (45deg dump) – horizontal arm	mm	1494	1465	1635	1689	1494	1494	1465	1635	1689	1494	523	599	652	705	523
Operating weight (includes 80Kg operator and full fuel tank)	kg	4873	4907	4938	4969	5020	5063	5097	5128	5159	5210	5927	5953	5994	6029	6031
V Pin height	mm	3120	3120	3120	3120	3120	3120	3120	3120	3120	3120	3340	3340	3340	3340	3340

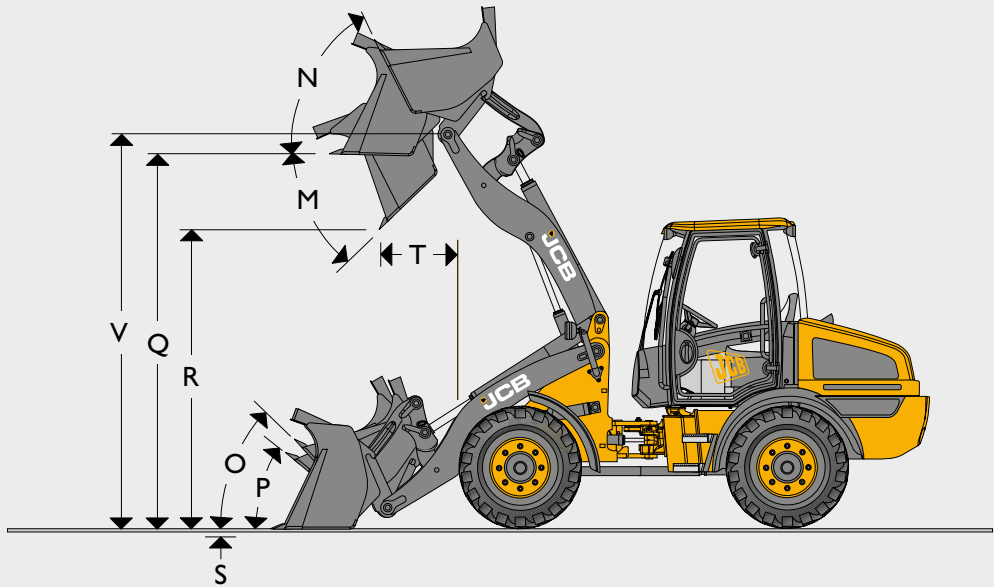

**TYRE SIZE – 406/407**

Tyre size	Manufacturer	Type	Op weight (kg)	Dimensions	
				Vertical (mm)	Width (mm)
335/80 R18	Dunlop	SPT9 EM	+41	-4	0
365/70 R18	Dunlop	SPT9 EM	+64	-14	+69
405/70 R18	Dunlop	SPT9 EM	+94	+9	+113
335/80 R20	Dunlop	SPT9 MPT	+77	+22	-22
335/80 R18	Michelin	XZSL	+82	+9	+14
340/80 R18	Michelin	XMCL	+72	-6	+25
340/80 R18	Nokian	TRI 2	+56	+1	+12
12.5-18	Camso	SLR4	0	0	0
12.5/80-18	Camso	SLR4	0	-15	-15

Loader dimensions quoted on 12.5-18 Wheels and Tyres.

**TYRE SIZE – 409**

Tyre size	Manufacturer	Type	Op weight (kg)	Dimensions	
				Vertical (mm)	Width (mm)
405/70 R18	Dunlop	SPT9 EM	-56	-24	-8
335/80 R20	Dunlop	SPT9 MPT	-73	-3	-85
365/80 R20	Dunlop	SPT9 MPT	-55	-17	-51
405/70 R20	Dunlop	SPT9 MPT	-14	+10	-7
375/75 R20	Michelin	XZSL	-1	-4	-13
380/75 R20	Michelin	XMCL	-13	-4	-15
400/70 R20	Michelin	XMCL	0	-4	+4
405/70 R20	Michelin	XZSL	+25	+19	+10
420/75 R20	Michelin	XMCL	+38	+23	+10
340/80 R18	Nokian	TRI 2	-82	-32	-65
360/80 R20	Nokian	TRI 2	-57	+10	-51

Loader dimensions quoted on 16.0/70-20 Wheels and Tyres.

**LOADER DIMENSIONS – FORK FRAME WITH FORKS**

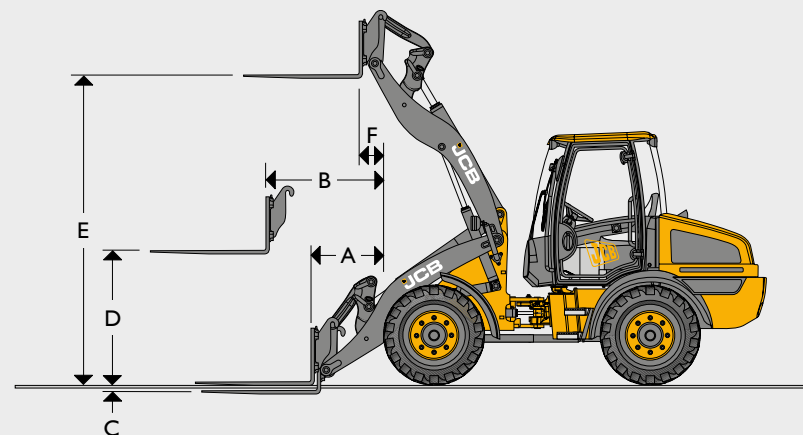

		Parallel fork			
		406	407	409	
	Fork carriage width	mm	1345	1345	1345
	Length of tines	mm	1200	1200	1200
A	Reach at ground level	mm	710	710	724
B	Reach at arms horizontal	mm	1232	1232	1187
C	Below ground level	mm	84	84	17
D	Arms, horizontal height	mm	1426	1426	1396
E	Arms, max. height	mm	3012	3012	3231
F	Reach at maximum height	mm	506	506	231
	Payload*	kg	2033	2142	2366
	Tipping load straight	kg	3184	3324	3787
	Tipping load full turn (40°)	kg	2541	2600	2907
	Attachment weight	kg	191	191	191

\* At the centre of gravity distance 500mm. Based on 80% of FTTL as defined in ISO 8313.

Manual fork spacings at 50mm increments. Fork section 100mm x 50mm.

ELECTRICAL SYSTEM			406/407/409
System voltage	Volt		12
Alternator output	Amp hour		80
Battery capacity	Amp hour		100

HYDRAULICS				
		406	407	409
Pump type		Tandem Gear Pump	Single Gear Pump	Single Gear Pump
Pump type for High Flow Option		N/A	2 x Single Gear Pump	2 x Single Gear Pump
Pump max. pressure	bar	230	230	250
Auxiliary flow	l/min	60	60	83
Hydraulic cycle times at max. engine	rpm			
Arms raise (full bucket)	Seconds	4.9	4.9	4.9
Bucket dump (full bucket)	Seconds	3.5	3.5	4.1
Arms lower (empty bucket)	Seconds	3.1	3.1	3
Total cycle	Seconds	11.5	11.5	12
Hydraulics (High Flow)			plus 30l	plus 30l
Pump max. flow	l/min	64	64	89

SERVICE FILL CAPACITIES			406/407/409
Hydraulic system	litres		70
Fuel tank	litres		80
Engine oil sump	litres		11.2
Axle oil (front)	litres		4.4
Axle oil (rear)	litres		6.05

STANDARD EQUIPMENT			
	406	407	409
<b>GENERAL MACHINE FEATURES</b>	Parallel lift geometry, JCB Hydraulic Quickhitch, articulated steering, front and rear fenders, one piece opening bonnet, recovery hitch, lifting lugs.	Parallel lift geometry, JCB Hydraulic Quickhitch, articulated steering, front and rear fenders, one piece opening bonnet, recovery hitch, lifting lugs, temperature controlled engine cooling fan.	
<b>TRANSMISSION</b>	Two speed, neutral start, inching function, forward/reverse switch on joystick control lever.		
<b>BRAKES</b>	In board oil immersed brakes with combined handbrake; cable operated parkbrake.		In board oil immersed brakes with combined handbrake; spring actuated hydraulic released parkbrake.
<b>ELECTRIC</b>	Full Road Lighting, Direction Indicators and Battery Isolator.		
<b>HYDRAULICS</b>	Single lever manual control, gear pump with priority steer, emergency steer back up.	Single lever servo control, gear pump with priority steer, emergency steer back up, flow sharing (409 only).	
<b>CAB</b>	ROPS/FOPS safety structure, fully adjustable seat, interior light, adjustable tilt steering column, safety glass, front and rear screen wash/wipe, 3 speed heater fan with replaceable filters, sun visor.	ROPS/FOPS safety structure, fully adjustable seat, interior light, adjustable tilt steering column, safety glass, LCD display, front and rear screen wash/wipe, 3 speed heater fan with replaceable filters, radio aperture (high spec cab only), sun visor.	

OPTIONAL EQUIPMENT			
	406	407	409
<b>GENERAL MACHINE FEATURES</b>	HBCV, 4th Spool aux circuit manual, LSD axles, fully opening RH window with lock back, immobiliser, livelink, under bonnet battery isolator, worklights, bio oil, shovel level indicator, stowage box. See Dealer for full list.	HBCV, 4th Spool aux circuit, LSD axles, locking differential front axle with on the fly operation (409 only), immobiliser, livelink, under bonnet battery isolator, worklights, bio oil, aircon, constant flow, high flow plus 30 l/min., SRS, 35kph on 407 40kph on 409, Rockinger Tow hitch 3.5t, rear aux. hydraulics, rear electrical connection, creep speed, shovel level indicator, stowage box, fully opening RH window with locks. See Dealer for full list.	

NOISE AND VIBRATION						
		406	407	409	Uncertainty	Measurement conditions.
Noise at the operator station	LpA	77	78 dB	76 dB	+/- 1 dB	Determined in accordance with the test method defined in ISO 6396 and the dynamic test condition defined on 2000/14/EC.
Noise emission from the machine LWA		101	101 dB	101 dB	+/- 1 dB	Guaranteed equivalent sound power (external noise) determined in accordance with the dynamic test conditions defined in 2000/14/EC.
Whole body vibration	m/s <sup>2</sup>	0.59	0.59	0.59	+/- 0.11 dB	ISO 2631-1:1997 normalised to an 8h reference period and based upon a test cycle comprising of loader work (soil).
Hand-arm vibration	m/s <sup>2</sup>	<2.5	<2.5	<2.5	N/A	ISO 5349-2:2001 dynamic test conditions.



**ONE COMPANY, OVER 300 MACHINES.**

Your nearest JCB dealer

**Wheel Loaders 406/407/409**

Max. Engine power: 36.4kW (49hp) / 48kW (64hp) / 54.5kW (74hp)

Max. Operating weight: 5020kg / 5210kg / 6031kg

JCB Sales Limited, Rocester, Staffordshire, United Kingdom ST14 5JP.

Tel: +44 (0)1889 590312 Email: [salesinfo@jcb.com](mailto:salesinfo@jcb.com)

Download the very latest information on this product range at: [www.jcb.com](http://www.jcb.com)

©2009 JCB Sales. All rights reserved. No part of this publication may be reproduced, stored in a retrieval system, or transmitted in any form or by any other means, electronic, mechanical, photocopying or otherwise, without prior permission from JCB Sales. All references in this publication to operating weights, sizes, capacities and other performance measurements are provided for guidance only and may vary dependant upon the exact specification of machine. They should not therefore be relied upon in relation to suitability for a particular application. Guidance and advice should always be sought from your JCB Dealer. JCB reserves the right to change specifications without notice. Illustrations and specifications shown may include optional equipment and accessories. The JCB logo is a registered trademark of J C Bamford Excavators Ltd.

