



## WHEEL LOADER | 411/417

411 – Operating weight: 8722kg Gross engine power: 81kW (109hp) Full turn tipping load: 5451kg Standard shovel capacity: 1.4m<sup>3</sup>

417 – Operating weight: 9602kg Gross engine power: 93kW (125hp) Full turn tipping load: 6042kg Standard shovel capacity: 1.6m<sup>3</sup>



## A **QUALITY** PROCESS.

WE KNOW THAT A WHEEL LOADER IS A KEY PART OF THE ON-SITE PROCESS. THAT'S WHY THE JCB 411 AND 417 ARE BUILT ON A FOUNDATION OF QUALITY AND RELIABILITY. THE PROCESSES WE'VE USED TO DESIGN AND MANUFACTURE THEM WILL SAFEGUARD YOUR WORKING PROCESS, HOUR AFTER HOUR, DAY AFTER DAY.

We use state-of-the-art manufacturing processes like robot machining, precision paint technology and innovative assembly techniques to achieve the very highest levels of quality.



### Designed to work hard.

- 1 Finite element analysis, as well as extensive endurance and rig testing ensure superior structural strength and durability. Cold cell testing guarantees starting performance down to  $-20^{\circ}\text{C}$ .
- 2 Precision machining provides high tolerances and accurate location of pins and bushes.
- 3 The 411 and 417 can be specified for heavy-duty applications like waste or corrosive material handling.



### Protecting ancillaries.

4 A solid cast rear counterweight protects the rear of your machine – including the rear lights and cooling pack – from damage.

5 You can opt for additional guards on the front screen, lights, underbelly and rear grille.

For additional protection, there are impact-resistant fender edges and trims fitted.

### Well articulated.

6 The articulation joint has a heavy-duty centre pin and oversized bush, as well as twin taper roller bearings on the bottom box joints. This can tolerate both vertical and horizontal loads for durability and rigidity.

7 Hoses are neatly routed and clamped through the articulation joint, well away from any pinch points. Steering rams are positioned high up and well protected from possible impact and site damage.

These machines have integral steel fluid tanks for the ultimate in leak protection; a far superior solution to the plastic tanks favoured by some competitors.



4



5

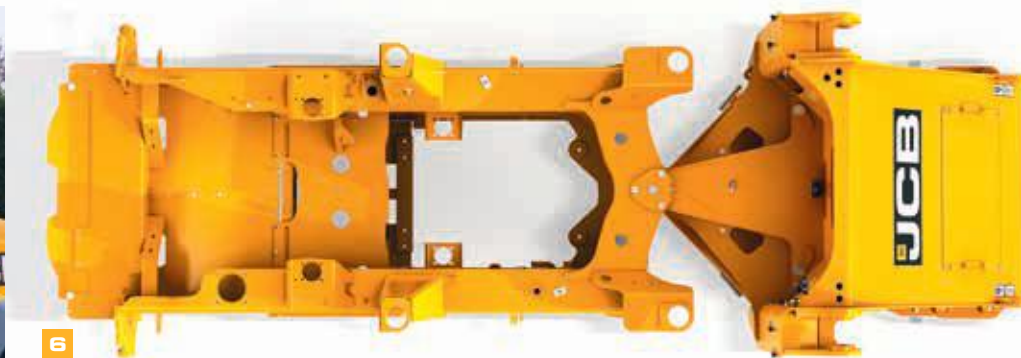

6



7



# PRODUCTIVE PERFORMANCE.

THE 411 AND 417 CAN PERFORM GREAT FEATS OF PRODUCTIVITY. WITH HIGH POWER AND TORQUE, BOTH MACHINES MEET TIER 4 FINAL EMISSIONS LEGISLATION WITHOUT THE NEED FOR PERIODIC REGENERATION.

## Engine productivity.

1 The EcoMAX 4.4 litre engine achieves maximum engine power (81kW (109hp) in the 411, 93kW (125hp) in the 417) and peak torque (516Nm in the 411 and 550Nm in the 417) at low revs for excellent response.

A variable geometry turbocharger provides increased performance at low engine speed for improved cycle times and tractive effort.

## Loading productivity.

2 JCB's optional quickhitch makes attachment changing quick and efficient. The quickhitch is designed to be compatible with aftermarket attachments too.

3 Powerful hydraulics result in fast cycle times. The 411 features a double gear pump, whilst the 417 model features a single variable displacement piston pump hydraulics which can circulate 123l/min on the 411 and 156 l/min on the 417 for increased productivity and excellent multi- function capability.

## COMMANDPLUS controls.

A choice of 3 or 4-spool hydraulics gives you the scope for invaluable extra versatility. Flow can be adjusted from the cab via the all-new Command Plus controls.



1

There's no need to worry about wasting time and money replacing a diesel particulate filter (DPF) on your loader; its EcoMAX engine meets Tier 4 Final/Stage IV legislation using only exhaust gas recirculation (EGR) and selective catalytic reduction (SCR). This setup also improves fuel economy.



2



3



### Loading productivity (continued).

4 So you can perform parallel lifting and use plenty of attachments, both machines are fitted with a high torque (HT) loader arm. This also provides excellent visibility to the attachment at all heights.

Choose from standard lift on either model, or choose high lift (HL) or super high lift (SHL) on the 417 and you can use the machine for higher loading height applications.

### Drivetrain productivity.

5 With a choice of axle options you can tailor performance to any application.

- > Open differentials are ideal for hard standing ground conditions.
- > Limited slip differential axles increase tractive effort and are perfect for soft muddy ground conditions.



## EFFICIENT BY DESIGN.

THE JCB 411 AND 417 ARE DESIGNED TO MOVE MORE MATERIAL FOR LESS. TO ACHIEVE THIS, WE'VE DESIGNED THE ENGINE, AXLES, DRIVELINE AND HYDRAULICS TO WORK IN HARMONY WITH EACH OTHER, FOR ULTIMATE EFFICIENCY AND DURABILITY.



### Powering it all.

**1** No DPF means unnecessary additional fuel piping is eliminated as is the potentially dangerous temperatures involved in regeneration. The fuel that would have been needed to restore your DPF can be used instead for actual productive work.

**2** EcoMAX produces high levels of power and torque at engine speeds as low as 1500-1600 rpm for efficient matching of transmission and hydraulics.

**3** High back-off brakes reduce viscous drag during roading and rehandling, which boosts fuel efficiency.





### Powering it all (continued).

4 A viscous coupled engine fan automatically adjusts its speed depending on ambient temperature, optimising cooling, saving fuel and lowering noise.

Operating specialist attachments is easy with an in-cab adjustable proportional auxiliary flow rate.

5 Our 4-speed transmission gives you a range of gears to suit a wide range of applications. The operator can choose from manual or automatic gear shifting at a press of a button.

Unloaded spool valves in the valve block mean that arms lower under gravitational, not hydraulic force, reducing fuel consumption.

JCB's innovative variable displacement pump feeds a load-sensing valve block which only consumes power on demand, providing precise, efficient loader control (417 only).

**COMMANDPLUS controls.**  
JCB Smoothride load suspension limits shock loadings and therefore reduces material spillage and structural stress, as well as increasing operator comfort. The speed of engagement is adjustable from within the cab using the latest state-of-the-art CommandPlus controls.



5



4



Adjustable SRS engagement speed.



Adjustable Auxiliary control.

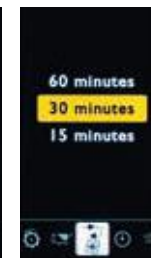

Adjustable reversing fan intervals.



# COMMANDPLUS.

THE LATEST JCB 411 AND 417 WHEEL LOADERS BOAST OUR ALL-NEW COMMAND PLUS CAB. THIS UNIQUE APPROACH TO ERGONOMICS IS THE RESULT OF A RADICAL RETHINK AND A RIGOROUS RESEARCH PROGRAMME. EXPECT BEST-IN-CLASS COMFORT, VISIBILITY, ERGONOMICS AND QUIETNESS.

## See the difference.

**1** You'll immediately notice the totally redesigned ROPS structure; this has allowed the A pillars to be moved to the same width as the rear of the cab, providing a larger interior with a superb panoramic front windscreen. All switches and auxiliary controls are now located on the right-hand A-pillar for easier access.

**2** Using your machine's simple, dedicated menu interface is easily done with an intuitive optional rotary controller.

**3** Operating your 411 or 417 loader is now easier than ever. All of the controls are seat-mounted, even going as far as to move with the seat suspension. You can also select the control system that's best for your operators: choose from single lever joystick or multi-lever configurations, all using electro-hydraulics for the ultimate in precision.

**4** There are two full colour LCD screens to navigate the operating menus, one of which doubles as a monitor for the optional rear-view camera and CommandPlus control menu.





The noise level in the cab is an incredibly low 68dB(a): so quiet you can hardly hear the engine running.

5 To keep the operator environment comfortable for working at all times, we've positively pressurised the cab to eliminate dust and fumes.

6 After extensive research into operator ergonomics, we've devised the Command Driving Position, which boasts the very optimal control layout for a multitude of different driver shapes and sizes available, ranging from an air suspension standard seat to a super deluxe half leather seat, featuring fully adjustable heating and cooling functionality, electrically adjustable lumbar support and adjustable dampers.

7 A set and forget feature makes operator access even easier. In short, your preferred steering wheel position is stored and can be instantly returned to, even after you've folded the wheel away.

Specify your 411 or 417 with either air conditioning or automatic climate control to create perfect working temperatures.

With a dedicated media port on board, you can be assured of superb connectivity for all your electronic devices.

A sliding window on both sides of the cab allows easy communication with people outside the machine.

The optional electronic handbrake offers numerous advantages: it's quick and easy to operate, and, because there's no cable, there are fewer holes in the cab. This helps to isolate the operator environment further.

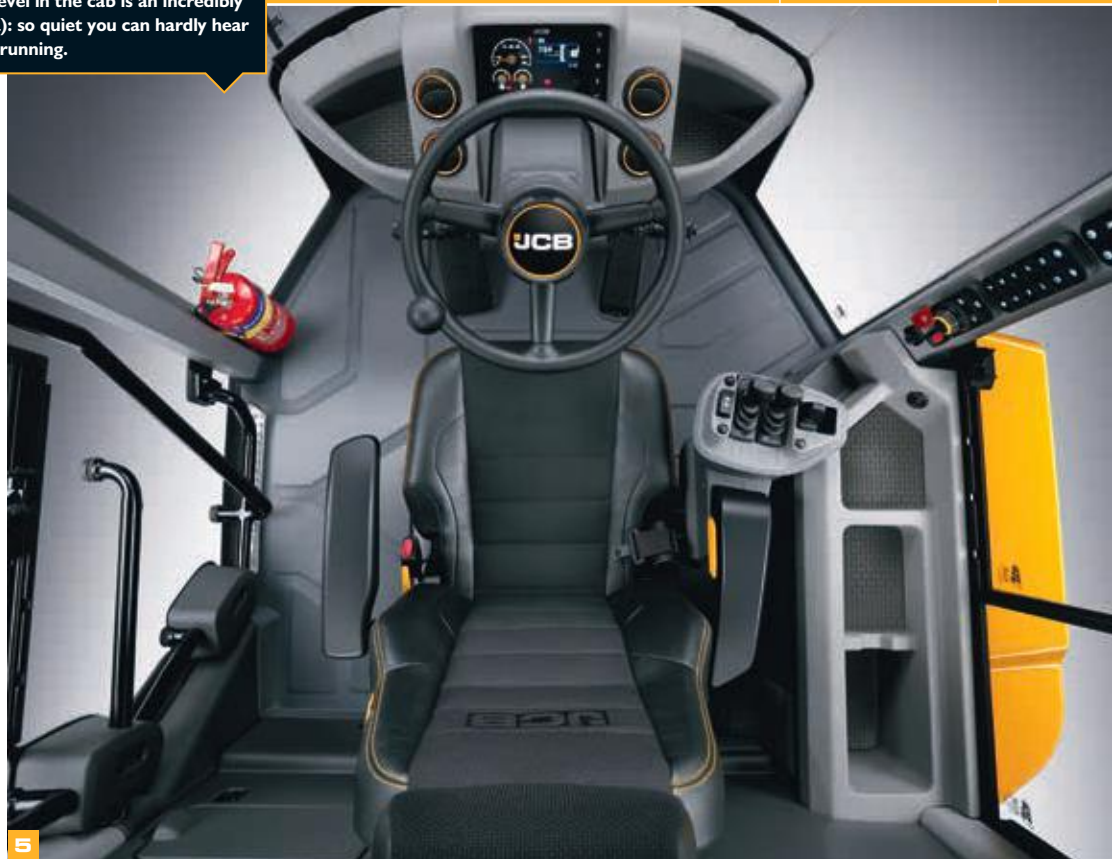



## LOW MAINTENANCE LONG INTERVALS.

WHEEL LOADERS NEED TO SPEND THE MAXIMUM AMOUNT OF TIME HARD AT WORK. WE'VE DESIGNED THE 411 AND 417 TO DO JUST THAT, WITH LONG SERVICE INTERVALS AND QUALITY COMPONENTS.

### Routine maintenance.

**1** Gain access to the engine bay and cooling pack areas easily with the compact single piece bonnet.

**2** Accessing the diesel and DEF (Diesel Exhaust Fluid) tanks is similarly straightforward. Both filler points are separated to avoid accidental cross-contamination when refilling.

You can check washer fluid level, engine oil and coolant from inside the cab, with all other routine checks and grease points located at ground level. This makes life both easier and safer.

Most Tier 4 Final/Stage IV engines use a costly Diesel Particulate Filter (DPF) that can cost a lot of money and time when it needs replacing. The EcoMAX engine is DPF-free, reducing your servicing and running costs.

**3** With the optional auto lubrication kit, your machine will take care of its own greasing requirements.





### Less servicing, more service.

**E** The CommandPlus cab relays machine condition giving real time alerts, safeguarding both the machine and operator.

The intuitive CommandPlus “help function” provides the operator with meaningful descriptions of the in-cab switch function. Using the “?” button, this allows new or unfamiliar operators to quickly and easily understand machine functions without having to refer to the operators manual.

**E** To prove how good EcoMAX engines are, we’ve tested them for 110,000 hours in 70 different machines across the toughest applications and environments.

Full hydraulic dual circuit braking with multiple oil immersed discs gives the braking system a virtually maintenance-free lifespan.

A cyclonic engine fan scavenge filter provides four times the filtering capacity of a standard air filter. It’s a longer life system, with fewer components and a higher level of efficiency, making for better engine protection.

There’s a large 116-litre fuel tank fitted, with optional 111 litre auxiliary fuel tank, which ensures maximum working hours between refills.



**COMMANDPLUS controls.**  
If you’re planning to use your wheel loader in environments with large amounts of airborne debris, opt for the adjustable reversing fan. The fan can be operated via the CommandPlus controls, and even swings out for easy cleaning access.





## DRIVE SAFELY.

THE NEW JCB 411 AND 417 ARE DESIGNED TO KEEP THE OPERATOR AND YOUR WORKSITE SAFE AT ALL TIMES. GREAT VISIBILITY, NON-SLIP SURFACES AND FULL ROPS/FOPS PROTECTION ARE JUST THE START.



### Safely does it.

- 1 Our optional rear-view camera displays an unobstructed rearward view on the in-cab colour monitor.
- 2 Superb visibility in dark conditions is guaranteed with JCB's optional LED worklights.
- 3 Interior mirrors, heated exterior mirrors and bonnet mirrors combine to offer excellent views to every corner of your machine, whilst the red and white chevron counterweight option aids machine visibility to passing vehicles and bystanders.





### Safely does it (continued).

4 Access steps on the 411 and 417 are inclined and equally spaced, complemented by well positioned grab handles for three points of contact at all times.

5 Full fender coverage flaps have been carefully designed to keep forward spray to a minimum for all tyre options. This increases safety and decreases debris build-up. The battery and tool box are lockable for added security.

6 The cab is isolator-mounted, compliant with ROPS/FOPS standards, and positively pressurised against dust. You can choose from fresh air and carbon filters as well.

7 Engines fitted with a DPF can pose an increased fire risk because extreme heat can be created in regeneration mode. The new 411 and 417 don't use DPFs, so this is no cause for concern.

8 Non-slip walkways and additional grab handle options allow for safe movement around the machine.





## LIVELINK, WORK SMARTER.

**LIVELINK IS AN INNOVATIVE SOFTWARE SYSTEM THAT LETS YOU MANAGE JCB MACHINES REMOTELY – ONLINE, BY EMAIL OR BY MOBILE PHONE. ACCESS EVERYTHING FROM MACHINE ALERTS TO FUEL REPORTS AND HISTORY INFORMATION, WITH ALL DATA STORED AT A SECURE CENTRE.**

### Productivity and cost benefits

By providing information like idle time monitoring and machine fuel consumption, JCB LiveLink helps reduce your fuel usage, saving money and improving productivity. Machine location information can help improve efficiency and perhaps even reduce insurance costs.



### Maintenance benefits

Manage machine maintenance easily – accurate hours monitoring and service alerts improve maintenance planning, while real-time location data helps you manage your fleet. Critical machine alerts and maintenance history records are also available.



### Security benefits

LiveLink's real-time geofencing alerts tell you when machines move out of predetermined zones, and real-time curfew alerts inform you of unauthorised usage. Further benefits include real-time location information.





# A GREAT BUSINESS DECISION.

WE'LL PROVIDE YOU WITH FIRST CLASS SUPPORT AND ASSISTANCE TO SUIT YOUR EXACT BUSINESS NEEDS RIGHT FROM DAY ONE. SO WHEREVER YOU ARE, YOUR MACHINE WILL ALWAYS PERFORM TO ITS FULL POTENTIAL – ONE OF MANY REASONS WHY STARTING A WORKING RELATIONSHIP WITH JCB IS A GREAT BUSINESS DECISION.

## Machine selection.

Your JCB dealer has the right technical knowledge and expertise to ensure that you assess all the machine options available to you. This includes rental options and new or used machine sales.

## Rebuild and Refurbishment Programme.

If your business isn't in a position to buy a brand new machine, then JCB's Rebuild and Refurbishment programme can help you to extend the service life of your current vehicle cost-effectively.

## Technical support.

All local JCB dealers have instant access to factory expertise and technical support to provide you with the maximum machine uptime. JCB's Global Parts Centres, meanwhile, deliver around 95% of all parts anywhere in the world within 24 hours.

## Component monitoring.

JCB machines benefit from a sophisticated component monitoring programme that provides preventative maintenance and oil sampling to keep everything working at its optimum level.

## Service support.

We offer a range of extended warranties, from JCB PremierCover (full comprehensive cover) to JCB PowertrainCover (engine, axles, transmission and hydraulic pump cover). Service agreements, as well as service-only or Repair and Maintenance contracts ensure that we have the up-time of your wheel loading shovel totally covered. Our dealer maintenance specialists around the world charge competitive labour rates, and offer non-obligation quotations as well as fast, efficient repair work.

## Finance and Insurance.

Finance and Insurance specialists are always on-hand to provide fast, flexible, competitive quotes. Naturally, packages can be tailored to suit your specific business needs.

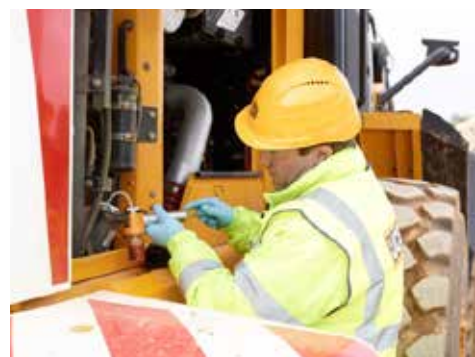



STATIC DIMENSIONS

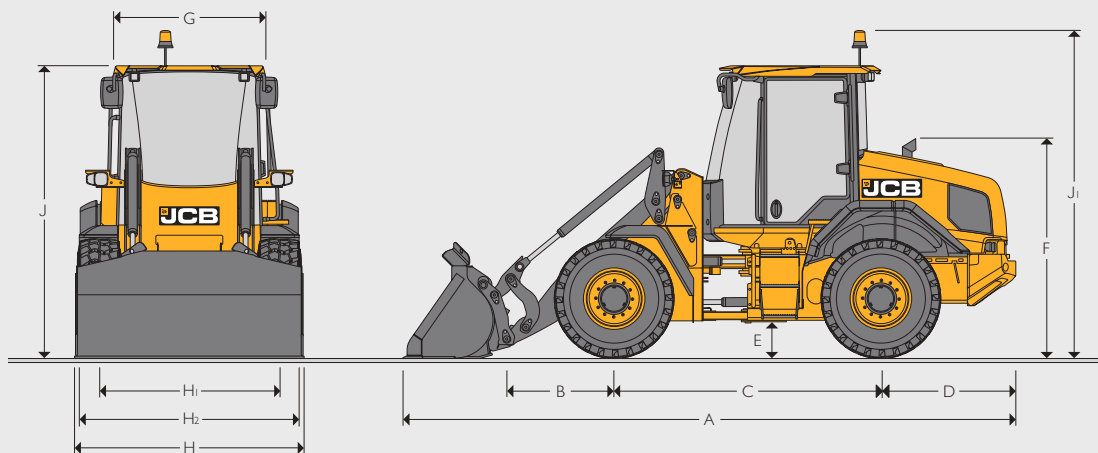

STATIC DIMENSIONS

			411 HT	417 HT	417 HT HL	417 HT SHL
A	Overall length	mm	6229	6290	6491	7143
B	Axle to pivot pin	mm	1226	1110	1311	1963
C	Wheelbase	mm	2750	2800	2800	2800
D	Axle to counterweight face	mm	1365	1365	1365	1365
E	Minimum ground clearance	mm	344	371	371	371
F	Height over exhaust	mm	2293	2300	2300	2300
G	Width over cab	mm	1431	1431	1431	1431
H	Maximum width over tyres	mm	2204	2328	2328	2328
H1	Wheel track	mm	1800	1880	1880	1880
J	Height over cab	mm	3057	3084	3084	3084
J1	Height over raised beacon	mm	3418	3445	3445	3445
	Front axle weight	kg	3457	3858	3973	4542
	Rear axle weight	kg	5327	5859	5794	5515
	Total weight	kg	8784	9717	9767	10057

411 data based on machine equipped with direct mounted 1.2 m<sup>3</sup> bucket with toe plates and Michelin 15.5R25 XHA (L3) radial tyres.

417 data based on machine equipped with direct mounted 1.6 m<sup>3</sup> bucket with toe plates and Michelin 17.5R25 XHA (L3) radial tyres.

TURNING CIRCLE

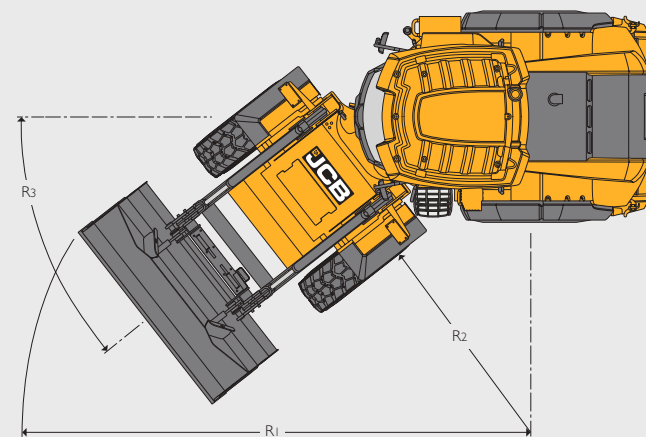

TURNING CIRCLE

			411 HT	417 HT	417 HT HL	417 HT SHL
R1	Maximum turn radius over shovel	mm	8750	9540	9605	10145
R2	Inside turn radius	mm	2658	2705	2705	2705
R3	Articulation angle	degrees	± 40	± 40	± 40	± 40



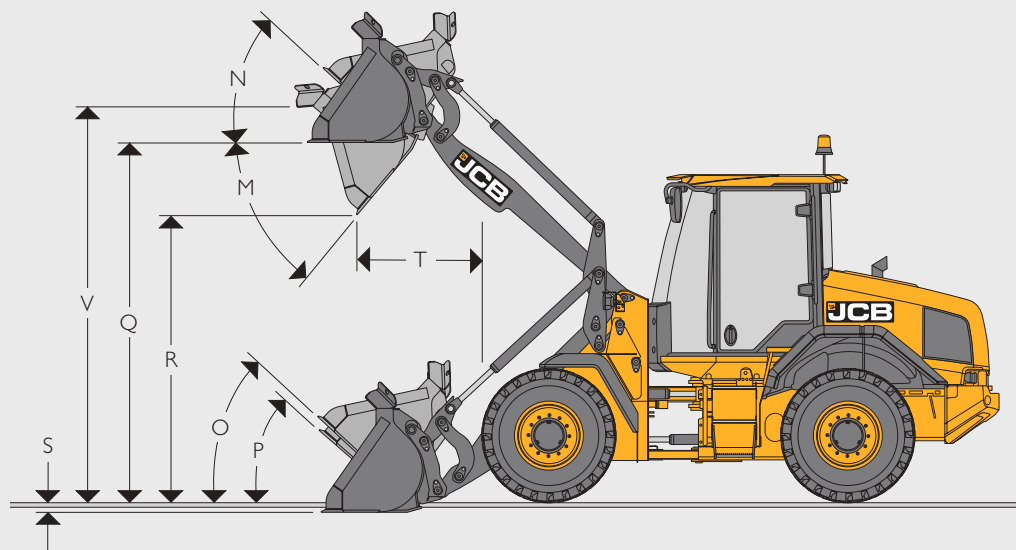

## TYRE SIZE 411 HT

Tyre size	Manufacturer	Type	Rating	Operating weight (kg)	HT		Dimensions	
					STL kg	F TTL kg	Vertical mm	Width mm
15.5-25	Goodyear	SGL D/L12 Ply	L2	-132	-88	-75	-9	-5
15.5-25	Goodyear	HRL D/L12 Ply	L3	-60	-40	-34	14	-5
15.5R25	Michelin	XTLA	L2	-44	-29	-25	-2	-7
15.5R25	Michelin	X-MINE D2	L5	640	426	362	54	14
17.5R25	Michelin	SNOPLUS	L2	276	184	156	25	84
17.5R25	Michelin	XTLA	L2	224	149	127	21	95
15.5R25	Nokian	LOADER GRIP 2	L3	-56	-37	-31	3	-10
17.5R25	Nokian	LOADER GRIP	L2	208	138	117	39	81

## LOADER DIMENSIONS 411 HT

Model	411 HT										
	Direct						Quickhitch				
Shovel mounting	General purpose						General purpose				
Shovel type	General purpose						General purpose				
Shovel equipment	Tipped teeth			Reversible toeplate			Tipped teeth			Reversible toeplate	
Shovel capacity (SAE heaped 100%)	m <sup>3</sup>	1.2	1.4	1.2	1.4	1.6	1.2	1.4	1.2	1.4	1.6
Shovel capacity (struck)	m <sup>3</sup>	1.01	1.18	1.01	1.18	1.36	1.01	1.18	1.01	1.18	1.36
Shovel width	mm	2250	2400	2250	2400	2400	2250	2400	2250	2400	2400
Shovel weight	kg	528	603	528	603	638	505	580	505	580	614
Maximum material density *	kg/m <sup>3</sup>	2328	1947	2328	1947	1677	2224	1851	2224	1851	1591
Tipping load straight *	kg	6537	6392	6537	6392	6299	6276	6106	6276	6106	6005
Tipping load full turn *	kg	5585	5451	5585	5451	5366	5337	5182	5337	5182	5091
Payload *	kg	2793	2726	2793	2726	2683	2669	2591	2669	2591	2546
Maximum breakout force	kN	73.2	67.7	73.2	67.7	62.7	67.2	62.3	67.2	62.3	57.1
M Dump angle maximum	degrees	47	47	47	47	47	47	47	47	47	47
N Roll back angle full height	degrees	41	41	41	41	41	41	41	41	41	41
O Roll back at carry	degrees	46	46	46	46	46	46	46	46	46	46
P Roll back at ground level	degrees	42	42	42	42	42	42	42	42	42	42
Q Load over height	mm	3344	3346	3344	3346	3345	3363	3365	3363	3365	3366
R Dump height (45 deg dump)	mm	2780	2718	2780	2718	2668	2749	2687	2749	2687	2638
S Dig depth	mm	132	130	132	130	131	113	113	113	113	113
T Reach at dump height	mm	926	978	926	978	1030	980	1042	980	1042	1084
V Pin height (maximum)	mm	3569	3569	3569	3569	3569	3569	3569	3569	3569	3569
Reach maximum (45 deg dump) horizontal arm	mm	1661	1724	1661	1724	1774	1719	1782	1719	1782	1832
Operating weight (includes 80kg operator and full fuel tank (includes auxiliary tank))	kg	8655	8722	8655	8722	8756	8864	8931	8864	8931	8965

\* Assumes machine is fitted with Michelin 15.5R25 XHA tyres.



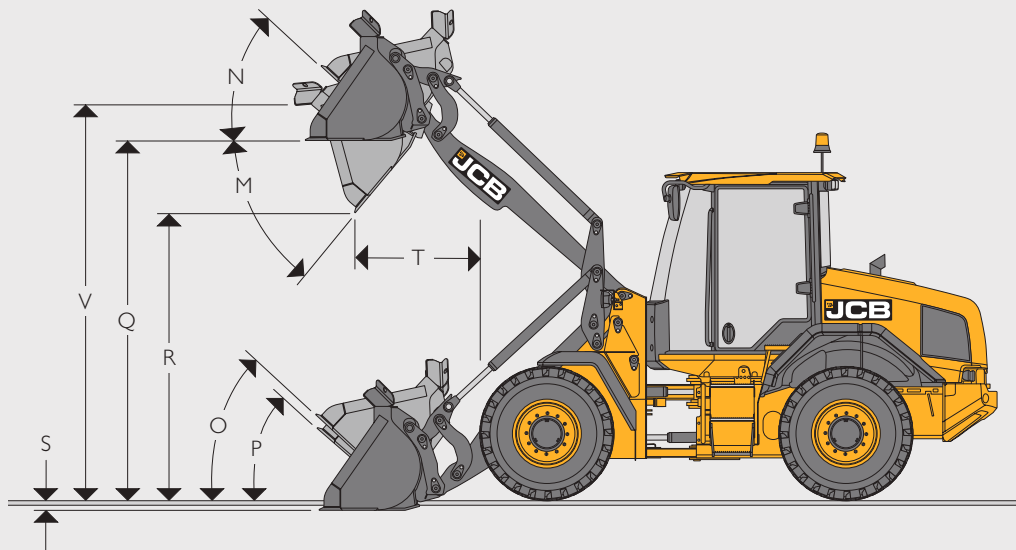

**TYRE SIZE 417 HT, HT HL, HT SHL**

Tyre size	Manufacturer	Type	Rating	Operating weight (kg)	HT		HT HL		HT SHL		Dimensions	
					STL kg	FTTL kg	STL kg	FTTL kg	STL kg	FTTL kg	Vertical mm	Width mm
17.5-25	Revolution	S2C2		1688	410	349	386	328	314	267	28	12
17.5-25	Revolution	SE		1688	410	349	386	328	314	267	28	12
17.5-25	Goodyear	SGL	L2	-184	-125	-106	-118	-100	-96	-82	2	9
17.5-25	Goodyear	HRL	L3	-52	-35	-30	-33	-28	-27	-23	15	2
17.5-25	Michelin	XTLA	L3	-92	-62	-53	-59	-50	-48	-41	-6	11
17.5-25	Michelin	XSNPLUS	L2	-40	-27	-23	-26	-22	-21	-18	-2	0
17.5-25	Michelin	X-MINE D2	L5	604	410	349	386	328	314	267	59	32
17.5-25	JCB	Earthmover	L3	104	70	60	66	57	54	46	31	-1
500/70R24	Michelin	XMCL		-196	-133	-113	-125	-106	-102	-87	1	163
17.5R25	Nokian	L GRIP	L2	-108	-73	-62	-69	-59	-56	-48	12	-3
17.5R25	BKT	XL GRIP	L3	-68	-46	-39	-43	-37	-35	-30	40	-3
600/55R26.5	Trelleborg	Twin Radial	Radial	140	95	81	90	77	73	62	23	388
20.5-25	Michelin	XHA	L3	504	342	291	324	277	262	223	62	180

**LOADER DIMENSIONS 417 HT, HT HL, HT SHL**

Model	417 HT								417 HT HL								417 HT SHL								
	Direct				Quickhitch				Direct				Quickhitch				Direct				Quickhitch				
Shovel mounting	General purpose				General purpose				General purpose				General purpose				General purpose								
Shovel type	Tipped teeth		Reversible toeplate		Tipped teeth		Reversible toeplate		Tipped teeth		Reversible toeplate		Tipped teeth		Reversible toeplate		Tipped teeth		Reversible toeplate		Tipped teeth		Reversible toeplate		
Shovel equipment	1.4	1.6	1.4	1.6	1.4	1.6	1.4	1.6	1.4	1.6	1.4	1.6	1.4	1.6	1.4	1.6	1.4	1.6	1.4	1.6	1.4	1.6	1.4	1.6	
Shovel capacity (SAE heaped 100%)	m <sup>3</sup>	1.18	1.36	1.18	1.36	1.18	1.36	1.18	1.36	1.18	1.36	1.18	1.36	1.18	1.36	1.18	1.36	1.18	1.36	1.18	1.36	1.18	1.36		
Shovel capacity (struck)	m <sup>3</sup>	1.18	1.36	1.18	1.36	1.18	1.36	1.18	1.36	1.18	1.36	1.18	1.36	1.18	1.36	1.18	1.36	1.18	1.36	1.18	1.36	1.18	1.36		
Shovel width	mm	2400	2400	2400	2400	2400	2400	2400	2400	2400	2400	2400	2400	2400	2400	2400	2400	2400	2400	2400	2400	2400	2400		
Shovel weight	kg	658	698	680	720	643	683	665	705	658	698	680	720	643	683	665	705	658	698	680	720	643	683	665	705
Maximum material density *	kg/m <sup>3</sup>	2189	1888	2189	1888	2088	1802	2088	1802	2039	1760	2039	1760	1945	1668	1945	1668	1499	1294	1499	1294	1419	1224	1419	1224
Tipping load straight *	kg	7236	7141	7236	7141	6932	6844	6932	6844	6748	6666	6748	6666	6469	6392	6469	6392	5038	4976	5038	4976	4803	4745	4803	4745
Tipping load full turn *	kg	6129	6042	6129	6042	5847	5767	5847	5767	5707	5632	5707	5632	5445	5337	5445	5337	4196	4139	4196	4139	3972	3918	3972	3918
Payload *	kg	3065	3021	3065	3021	2924	2884	2924	2884	2854	2816	2854	2816	2723	2669	2723	2669	2098	2070	2098	2070	1986	1959	1986	1959
Maximum breakout force	kN	70	64.6	70	64.6	64.9	59.9	64.9	59.9	70	64.6	70	64.6	64.9	59.9	64.9	59.9	70	64.6	70	64.6	64.9	59.9	64.9	59.9
M Dump angle maximum	degrees	50	50	50	50	51	50	51	50	47	47	47	47	47	46	47	46	45	45	45	45	45	45	45	45
N Roll back angle full height	degrees	43	43	43	43	43	43	43	43	43	43	43	43	43	43	43	43	47	47	47	47	47	47	47	47
O Roll back at carry	degrees	44	44	44	44	43	43	43	43	43	43	43	43	43	43	43	43	45	45	45	45	45	47	45	47
P Roll back at ground level	degrees	41	41	41	41	41	41	41	41	42	42	42	42	42	42	42	42	44	43	44	43	43	45	43	45
Q Load over height	mm	3341	3343	3341	3343	3339	3358	3339	3358	3559	3554	3559	3554	3568	3567	3568	3567	4202	4199	4202	4199	4216	4216	4216	4216
R Dump height (45 deg dump)	mm	2714	2666	2714	2666	2661	2631	2661	2631	2930	2878	2930	2878	2890	2839	2890	2839	3575	3522	3575	3522	3538	3488	3538	3488
S Dig depth	mm	110	109	110	109	92	92	92	92	116	111	116	111	96	96	96	96	148	152	148	152	132	132	132	132
T Reach at dump height	mm	930	973	930	973	993	1031	993	1031	986	1034	986	1034	1046	1097	1046	1097	1074	1122	1074	1122	1130	1180	1130	1180
V Pin height (maximum)	mm	3566	3566	3566	3566	3566	3566	3566	3566	3946	3946	3946	3946	3946	3946	3946	3946	4411	4411	4411	4411	4411	4411	4411	4411
Reach maximum (45 deg dump) horizontal arm	mm	1639	1688	1639	1688	1697	1746	1697	1746	1790	1839	1790	1839	1848	1897	1848	1897	2319	2369	2319	2369	2377	2427	2377	2427
Operating weight (includes 80kg operator and full fuel tank (includes auxiliary tank))	kg	9567	9602	9567	9602	9777	9812	9777	9812	9617	9652	9617	9652	9827	9862	9827	9862	9907	9942	9907	9942	10117	10452	10117	10152

\* Assumes machine is fitted with Michelin 17.5 R25 XHA tyres.



LOADER DIMENSIONS – FORK FRAME WITH FORKS

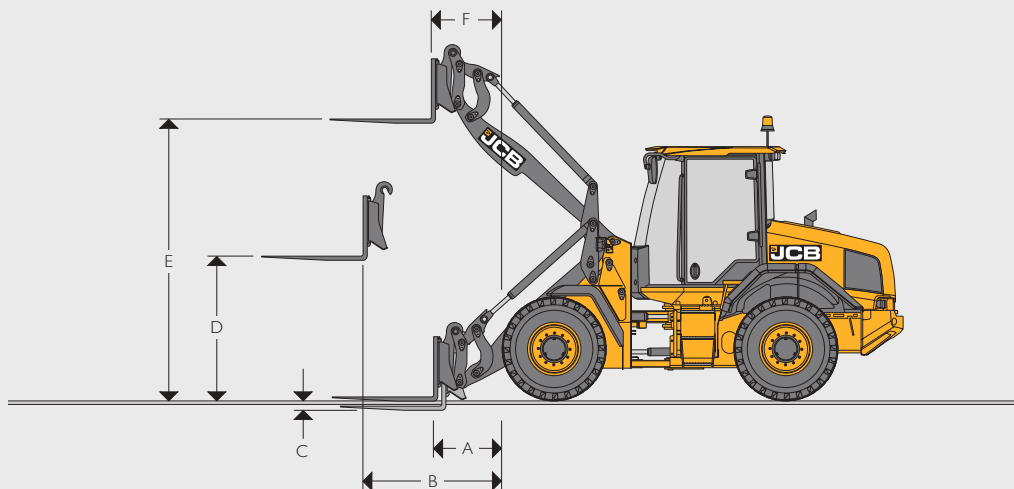

LOADER DIMENSIONS – FORK FRAME WITH FORKS

		Parallel fork				Non parallel fork			
		411 HT	417 HT	417 HT HL	417 HT SHL	411 HT	417 HT	417 HT HL	417 HT SHL
Fork carriage width	mm	1500	1500	1500	1500	1500	1500	1500	1500
Length of tines	mm	1220	1220	1220	1220	1220	1220	1220	1220
A Reach at ground level	mm	924	787	969	1620	923	785	984	1631
B Reach at arms horizontal	mm	1527	1459	1590	2115	1512	1447	1596	2118
C Below ground level	mm	78	57	55	79	62	68	64	88
D Arms, horizontal height	mm	1671	1745	1744	1744	1626	1735	1735	1735
E Arms, maximum height	mm	3395	3395	3618	4267	3414	3385	3599	4257
F Reach at maximum height	mm	823	829	806	846	776	817	819	853
Payload*	kg	3360	3722	3482	2630	3477	3714	3466	2622
Tipping load straight	kg	4948	5480	5172	3977	5093	5505	5150	3965
Tipping load full turn (40°)	kg	4200	4653	4353	3288	4346	4642	4333	3278
Attachment weight	kg	435	435	435	435	430	430	430	430

Assumes the fitment of Michelin 15.5R25 XHLA (L3) tyres for 411 and Michelin 17.5R25 XHA (L3) tyres for 417.

Manual fork spacing's at 50mm increments. Fork section 100mm x 50mm.

\* At the centre of gravity distance 500mm. Based on 80% of FTTL as defined in ISO 8313.

BUCKET SELECTOR

Material	Loose density (kg/m³)	Fill factor (%)
Snow (fresh)	200	110
Peat (dry)	400	100
Sugar beet	530	100
Coke (loose)	570	85
Barley	600	85
Petroleum coke	680	85
Wheat	730	85
Coal bituminous	765	100
Fertiliser (mixed)	1030	85
Coal anthracite	1046	100
Earth (dry) (loose)	1150	100
Nitrate fertiliser	1250	85
Sodium chloride (dry) (salt)	1300	85
Cement Portland	1440	100
Limestone (crushed)	1530	100
Sand (dry)	1550	100
Asphalt	1600	100
Gravel (dry)	1650	85
Clay (wet)	1680	110
Sand (wet)	1890	110
Fire clay	2080	100
Copper (concentrate)	2300	85
Slate	2800	100
Magnetite	3204	100

411 - HT

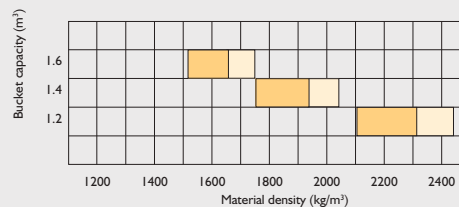

417 - HT

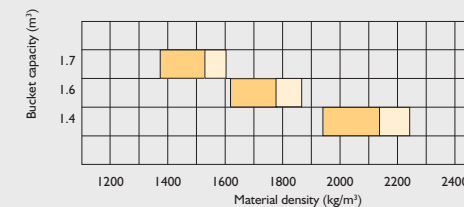

417 - HT HL

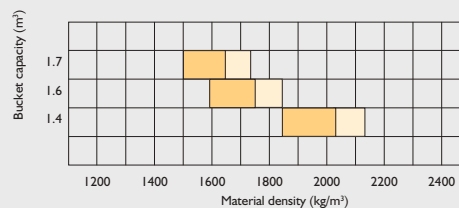

417 - HT SHL

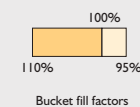
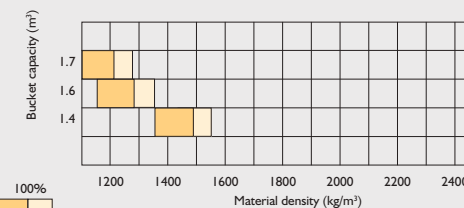



ENGINE			
		411	417
Type		4 stroke direct injection	4 stroke direct injection
Model		JCB EcoMAX T4F	JCB EcoMAX T4F
Capacity	litres	4.4	4.4
Bore	mm	103	103
Stroke	mm	132	132
Aspiration		Turbo charged	Turbo charged
Cylinders		4	4
Maximum gross power to SAE J1995/ISO 14396	kW (hp) @ 2200rpm	81.3 (109)	93 (125)
Maximum torque	Nm	516@1450	550@1500

TRANSMISSION					
		411		417	
		Smooth shift Powershift			
Type / Model		ZF 4WG115			
Torque convertor stall ration		3.01:1		2.3:1	
		Forward	Reverse	Forward	Reverse
<b>40kph</b>					
1 <sup>st</sup> gear	kph	5.5	5.8	5.4	5.7
2 <sup>nd</sup> gear	kph	13	13.7	12.8	13.5
3 <sup>rd</sup> gear	kph	28.8	30.1	28.4	29.8
4 <sup>th</sup> gear	kph	40	-	40	-
<b>50kph</b>					
1 <sup>st</sup> gear	kph	7.4	7.7	7.2	7.6
2 <sup>nd</sup> gear	kph	17.1	18	16.9	17.8
3 <sup>rd</sup> gear	kph	36.5	38.1	36.3	38
4 <sup>th</sup> gear	kph	50	-	50	-

LOADER HYDRAULICS			
		411	417
Pump type		Double gear pump	Variable placement piston pump
Pump 1 maximum flow	l/min	50.6	156
Pump 1 maximum pressure	bar	220	240
Pump 2 maximum flow	l/min	72.6	-
Pump 2 maximum pressure	bar	230	-
<b>Hydraulic cycle times at full engine revs</b>		<b>411</b>	<b>417</b>
Arms raise (full bucket)	Seconds	5.0	4.9
Bucket dump (full bucket)	Seconds	1.1	2.1
Arms lower (empty bucket)	Seconds	3.7	3.3
Total cycle	Seconds	9.8	10.3

AXLES			
411			
Type		Epicyclic hub reduction	
Make & model	Standard fit	JCB PD70 (front & rear)	
Overall axle ratio 40kph		18.16:1	
Overall axle ratio 50kph		13.71:1	
Rear axle oscillation		± 11°	
417			
Type		Epicyclic hub reduction	
Make & model	Standard fit	JCB PD87 (front & rear)	
Overall axle ratio 40kph		20.18:1	
Overall axle ratio 50kph		15.22:1	
Rear axle oscillation		± 11°	

<b>STEERING</b>	Hydraulic power steering system with emergency steering.
<b>BRAKES</b>	Hydraulic power braking on all wheels. In board mounted, oil immersed, multi-plate disc brakes. Mechanically or Electro-Hydraulically activated disc type parking brake operating on transmission output shaft.
<b>CAB</b>	In-cab noise level – 68dB(A). External Noise 103dB(A).

ELECTRICAL SYSTEM			
		411	417
System voltage	Volt	24	
Alternator output	Amp hour	100	
Battery capacity	Amp hour	2 x 110	

SERVICE FILL CAPACITIES			
		411	417
Hydraulic system	litres	155	
Fuel tank	litres	116	
Auxiliary fuel tank	litres	111	
DEF	litres	20	

NOISE AND VIBRATION				
		Uncertainty		Measurement conditions.
Noise at the operator station	LpA	68 dB	+/- 1 dB	Determined in accordance with the test method defined in ISO 6396 and the dynamic test condition defined on 2000/14/EC.
Noise emission from the machine	LWA	103 dB	+/- 1 dB	Guaranteed equivalent sound power (external noise) determined in accordance with the dynamic test conditions defined in 2000/14/EC.
Whole body vibration	m/s <sup>2</sup>	0.58	+/- 0.11 dB	ISO 2632-1:1997 normalised to an 8h reference period and based upon a test cycle comprising of loader work (soil).
Hand-arm vibration	m/s <sup>2</sup>	<2.5	N/A	ISO 5349-2:2001 dynamic test conditions.

## EQUIPMENT

## SERVICE AND MAINTENANCE

5 year LiveLink telematics	•
Engine oil remote drain and fill	•
Grouped pressure test points	•
Lockable tool box	•
Lubrication points accessible from ground level	•
Transmission oil level sight gauge	•
Hydraulic level sight gauge	•

## ENGINE

Air cleaner – cyclonic pre-filter with engine fan scavenge system	•
Fixed viscous mounted fan	•
Automatically reversing cooling fan	+
Crankcase breather oil trap	•
DEF fluid	•
Epoxy coated radiator / coolers	+
Fuel filter	•
Fuel pre-filter with water trap	•
Hydraulically driven cooling fan	•
-20° cold start	•
SCR engine emission control	•
Waste gated turbo	•
Widecore radiator	•

## ELECTRICAL

100 amp alternator	•
Amber rotating beacon	•
Electrical adjustable mirrors	•
Heated mirrors	•
External battery isolator	•
Fold down beacon arm	•
Halogen front and rear working lights	•
Full road light kit	•
Integrated rear view camera	+
LED front and rear working lights	+
LED 360° work lights	+
Number plate light kit	+
Radio wiring and speakers	•
Reverse alarm	•
Smart reverse alarm	+
White noise reverse alarm and light	+

## DRIVE TRAIN

4 speed transmission 20kph	+
4 speed transmission 40kph	+
Gear kick down on loader control lever	•
Loader lever direction control	•
Neutral start	•
Open differential	•
Limited slip differentials front and rear	+
Oscillating rear axle	•
Foot brake operated transmission disconnect (selectable)	•
Selectable automatic powershift	•
Speed limiter 20kph	+
Steering column single lever shift control (direction and gear)	•
Transmission cooler bypass	+

## BRAKE SYSTEM

Multi-plate wet disc brakes	•
Parking disc brake on transmission output shaft	•
Mechanical hand operated park brake	•
Electrical hydraulic park brake	+
Independent accumulator backup for electric park brake	+

## OPERATOR STATION

Fully glazed cab	•
Front windscreen guards	+
Air conditioning	•
Climate control	+
Single lever joystick	•
Multi-lever hydraulic controls	+
Proportional electro-hydraulic auxiliary control	+
Electronic adjustment of SRS (Smooth Ride System) cut-in speed	+
Electronic adjustment of reverse fan interval	+
Air suspension cloth seat	•
Deluxe heated air suspension cloth seat	+
Super deluxe heated & cooled air suspension half leather seat	+
Front roller blind	•
Rear roller blind	+
Cab air intake filter	•
Carbon cab air intake filter	+
12V in cab power socket	•
2 x 12V in cab power socket	+
24V in cab power socket	+
Reversing camera (colour)	+
Fold away adjustable steering column	•
ROPS / FOPS safety structure	•
Interior light	•

## OPERATOR STATION (CONTINUED)

Front primary display screen	•
Secondary A post display screen, rotary control menu interface	+
A post mounted membrane switches	•
50 mm seatbelt	•
75 mm seatbelt	+
Fire extinguisher (UK & USA only)	+
Two speed intermittent front windscreen wipe / wash and self-park	•
Single speed rear windscreen wipe/wash and self-park	•
3 speed heater/demisting	•
LH and RH sliding opening windows	•
Floor mat	•
Cup holder	•
Steering wheel spinner knob	•
Internal rear view mirror	•
Tinted cab glass	•
Multimedia port (USB and 3.5mm)	+
Operator stowage	•
Laminated windscreen	•
Heated rear screen	•
Loader control isolator	•
Horn	•
Adjustable armrest	•
Removable storage rubber mats	•

## FRONT PRIMARY DISPLAY

## Warning lights

Direction indicators	•
Master warning	•
High coolant temperature	•
Battery charging condition	•
Low fuel level	•
Engine oil pressure	•
Hazard lamps	•
Park brake state	•
Road lights	•
Main beam lights	•
Rear fog lights	•
Engine pre-heat	•
Brake system pressure	•
Low steering pressure	•

## Buzzer alerts

Engine air filter blocked	•
Diesel exhaust fluid (DEF)	•
Torque reduction in case of malfunction	•
Amber warning lamp	•



## EQUIPMENT

## FRONT PRIMARY DISPLAY (CONTINUED)

Guage display	
Engine speed	•
Coolant temperature	•
Fuel level	•
LCD screen display	
Current gear	•
Torque reduction in case of malfunction	•
Amber warning lamp	•
Diesel exhaust fluid (DEF)	•
Secondary steer system pressure	•
Steer mode	•
Ground speed	•
Engine Speed (numeric display)	•
Clock	•
Hydraulic state	•
SRS (Smooth Ride System)	+
Beacon	•
Front work lamps	•
Rear work lamps	•
Heated rear screen	•
Transmission sump temperature	•
Data screens	
DEF level	•
Hydraulic oil temperature	•
Torque convertor temperature	•
Volume of fuel remaining	•
Total fuel used (resettable)	•
Instantaneous fuel use	•
Average fuel use (resettable)	•
Current date	•
Machine hours	•
Trip distance (resettable)	•
Hours to service	•
Daily checks	•
Engine oil level	•
DEF level	•
RIGHT HAND SECONDARY DISPLAY - OPTIONAL	
Clock	•
Climate control	•
Fan speed	•
In-cab temperature set	•
Machine hours	•
Rear view camera	•
Fuel use	•

## RIGHT HAND SECONDARY DISPLAY - OPTIONAL (CONTINUED)

Time and date	•
Auxiliary flow rate	+
Hydraulic oil temperature	•
Transmission oil temperature	•
Machine settings screen	
Coolant temperature	•
Engine oil pressure	•
Air filter	•
Transmission sump temperature	•
Transmission torque convertor temperature	•
Hydraulic oil temperature	•
Battery voltage	•
Help display	•
On-screen handbook	•
HYDRAULIC SYSTEM	
Smoothride system (SRS)	+
Hydraulic quickhitch with in-cab isolation	+
Auxiliary ARV kit	+
Auxiliary hydraulic service	+
Twin auxiliary hydraulic service	+
Emergency steer back-up	•
JCB biodegradable hydraulic oil	+
Electronic hydraulic isolation	•
Automatic boom kick-out. Detent	•
Automatic bucket positioner	•
Front loader float	•
Hydraulic oil cooler	•
EXTERNAL EQUIPMENT	
Front and rear fenders	•
Front adjustable mud flaps	•
Front wheel spray guards	•
Automatic greasing system	+
Grease gun and cartridge	+
Mesh air intake screens	•
Flexible bottom step	•
Full width rear counterweight	•
Chevron rear counterweight	+
Recovery hitch	•
Lifting / tie down lugs	•
Auxiliary fuel tank	+

## PROTECTIVE EQUIPMENT

Front cab screen guards	+
Wastemaster package: includes front and rear light guards, front screen guard, Wastemaster decal.	+
Rear grille guard	+
Loader arm safety strut	•
Light guards	+
Belly guard kit	+
Articulation joint safety strut	•

## OTHER EQUIPMENT

High lift loader end (417 only)	+
Super high lift loader end (417 loader only)	+

STANDARD •

OPTIONAL +







**ONE COMPANY, OVER 300 MACHINES.**

Your nearest JCB dealer

### Wheel Loader 411/417

411/417 – Operating weight: 8722kg/9602kg Gross engine power: 81kW (109hp)/93kW (125hp)  
 Full turn tipping load: 5451 kg/6042kg Standard shovel capacity: 1.4m<sup>3</sup>/1.6m<sup>3</sup>

JCB Sales Limited, Rocester, Staffordshire, United Kingdom ST14 5JP.  
 Tel: +44 (0)1889 590312 Email: [salesinfo@jcb.com](mailto:salesinfo@jcb.com)  
 Download the very latest information on this product range at: [www.jcb.com](http://www.jcb.com)

©2009 JCB Sales. All rights reserved. No part of this publication may be reproduced, stored in a retrieval system, or transmitted in any form or by any other means, electronic, mechanical, photocopying or otherwise, without prior permission from JCB Sales. All references in this publication to operating weights, sizes, capacities and other performance measurements are provided for guidance only and may vary dependant upon the exact specification of machine. They should not therefore be relied upon in relation to suitability for a particular application. Guidance and advice should always be sought from your JCB Dealer. JCB reserves the right to change specifications without notice. Illustrations and specifications shown may include optional equipment and accessories. The JCB logo is a registered trademark of J C Bamford Excavators Ltd.



9999/5762 en-GB 05/17 Issue 3 (T4F)

