

131X
SERIES



INTRODUCING THE NEXT IN THE X SERIES

Our vision from the start was to design and engineer our most advanced tracked excavator range ever.

The new JCB 13 tonne machine sits perfectly alongside its highly acclaimed 20 tonne big brother.

Our engineering teams have once again obsessed over every minute detail of this new world-class excavator and used the same quality materials and proven components.

The result is another machine in the X SERIES to be taken seriously. Another machine to be trusted.

Anthony Bamford.

LORD BAMFORD, CHAIRMAN, JCB

EXTREME STRENGTH

It's taken 4 years of hydraulic, electronic and electrical development and thousands of hours of extreme endurance testing, to build you a machine that doesn't just look extremely strong, it is extremely strong.



EXTREME STRENGTH

Tested to extremes.

1 Whole machine shaker rig used to replicate 15,000 hours of tracking and vibration.

Our latest dig end which has been proven by machines across the globe.

Exhaustive testing on purpose built electronics and electric rigs to prove connections, layout and software.

2 30,000 window and door operation tests completed to prove components quality.

3 Hot and cold climate testing (55°C to -30°C) performed in controlled conditions and locations around the world.

Exceptional build quality

4 Proven undercarriage with fully-welded X frame construction for long-term durability with components supplied by industry-leading suppliers.

5 Rigid upper frame, flat revolver side skirts and double skinned doors with new plated hinges provide greater strength.

Extremely robust fold back mechanism for cab mirror.

Finite Element Analysis ensures longer life for key components.



EXCEPTIONAL COMFORT

We've used ergonomic design, automotive quality materials and engineering excellence to deliver exceptional comfort. And with ride comfort and the quietest cab in its class, there's enough to make even the most demanding operator extremely happy.



Best operator environment.

1 Spacious JCB CommandPlus cab with high quality injection moulded interior. Industry-leading Grammer seat with wide, adjustable arm rests that reclines 145°.

New track pedal design with T-bars as standard with non-slip coating and optimised ergonomics.

2 Joystick and switch controls are mounted to pods which are suspended from the seat and move with the operator for optimum control and less fatigue.

3 Powerful new HVAC, with 11 targeted vents for optimum performance in hot and cold environments. Climate control comes as standard.

4 Industry standard isolator lever operation prevents accidental activation when exiting the cab.

5 Spacious luggage tray behind operators seat with 3 independent 12V power supplies. Another handy storage space can be found at the back of the cab in the roof liner, including a hanger for the operator's helmet.

6 The Bluetooth radio, fitted as standard, is fully integrated into the control screen.

Roof, front, rear and side window blinds comes as standard providing full cab coverage.



1



2



3



4



5



6

EXCELLENT CONTROL

**4 years of hydraulic development combined with proven Japanese components
have delivered the very best balance of controllability and efficiency.**



EXCELLENT CONTROL



Effortless working.

- 1** Proven Japanese hydraulics deliver precise and efficient control.
 - 2** Operator can select Auto-Stop and Auto-Idle depending on preference.
 - 3** Customisable proportional controls allow the operator to set their preference of speed and control of attachments.
- Dozer option adds extra versatility.
- Power boost button increases pressure by 9% for up to 9 seconds to provide extra tearout in tough conditions.
- 4** Tracking speed can be found on the joystick for on the move tracking change, whilst a convenience button lets you configure a range of functions such as radio mute, camera cycle, or front screen wash.
 - 5** Slew drive provides high torque on acceleration and braking for greater controllability and refinement.



EXTREMELY EASY

Using latest ergonomic design and with the help of customer and operator feedback, the new I31X has been designed to have best-in-class ease of use when working in any application.



Best-in-class ease of use.

1 Start-stop button for ease of start-up means the operator doesn't have to turn the key to start it back up again. The start sequence also allows you to start digging within 2 seconds.

An intuitive menu navigation can be configured into multiple languages to suit most operators.

2 Pipework shut-off taps now added as standard with SAE fittings, to enable quick connection of attachments when taking a hydraulic option.

3 Advanced tool select system improves attachment handling by monitoring pressure and flow. There is tool storage as standard for up to 10 tools.

4 Easy quickhitch provides simplified operation with an override for removing large breakers or fork attachments.

5 Factory ready option to facilitate easy fitment of 2D and 3D Topcon, Trimble, Leica GPS systems.

6 The cab includes mounts as standard to allow guards to be fitted in the field and also includes flat front glass for easy replacement.



1



2



3



4



5



6

EXPERIENCE GREATER PERFORMANCE

We've invested years of research and development and listened to thousands of customers like you to build a machine that's ready to perform in the most extreme conditions, on any job site.



EXPERIENCE GREATER PERFORMANCE

Best-in-class productivity.

- 1** Hydraulic pipes and hoses have a large diameter for increased productivity and efficiency. An innovative hydraulic regeneration system means oil is recycled across the cylinders for faster cycle times and reduced fuel consumption.
- 2** Auto-stop and Auto-idle on the JCB's Dieselmax 430 TCA EU Stage V compliant engine provides fuel saving of up to 5%.
- 3** For extra versatility, JCB offers a full list of auxiliary pipework options including hammer, merged pump flow, auxiliary, and low flow.
- 4** Machine cooling in 55°C heat with air conditioning running has been achieved with a 15% larger hydraulic cooler for optimum airflow.
- 5** The I31X Stage V has no DEF requirement by using a DOC and DPF for the exhaust after treatment. Resulting in lower running costs.



EXTRAORDINARY ATTENTION TO DETAIL

Building the new I31X involved a huge investment in state-of-the-art automotive style production facilities.

We introduced new tooling, EPD coating, robot welding and established new relationships with many industry-leading suppliers to bring you not just great excavators but exceptional ones.

World-class finish.

1 All components are painted in house using a state-of-the-art paint facility to deliver a high quality finish that's checked for paint adhesion and coverage.

All machines undergo 1,232 validation checks including an intense hot test focusing on vibration, pressure and heat to replicate real-life applications.

2 Significantly reduced vented and open areas means inherently stronger bodywork and reduced painted edges.

3 Doors are bolted directly to the house frame and remain rust-free due to a zinc coating on all wear faces. All fasteners have a zinc finish (Geomet) for improved corrosion resistance, a new bolt and washer design protects paint from damage.

4 New recessed counterweight design protects the rear end and machine branding from impact damage.

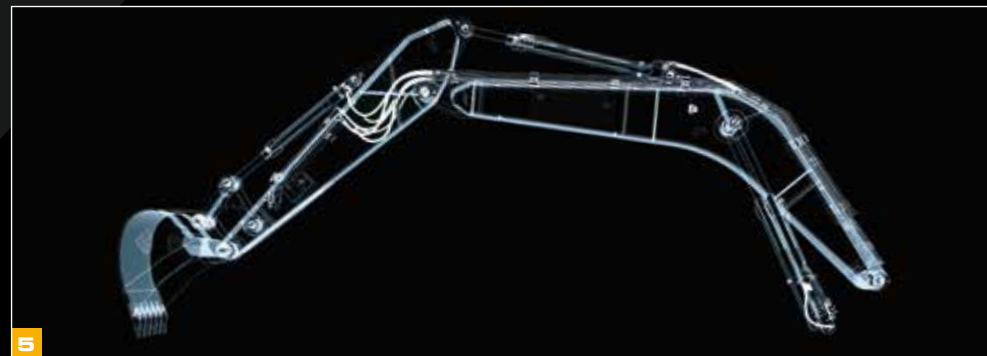

World-class assembly.

5 Robot welding of the dig end and undercarriage ensures consistent quality and accuracy.

6 The slew ring mounting face is machined after manufacturing and welding to ensure a flat surface that reduces slewing noise.

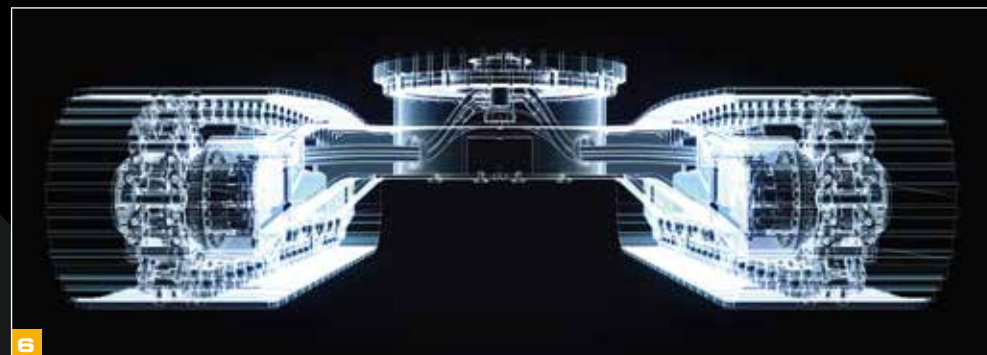

EXTENDED SERVICE INTERVALS

The new I31X has been designed with greater productivity in mind and that means spending more time working and less time being serviced. Longer service intervals, quality parts and easy access to maintenance points all help to save you time and money.



EXTENDED SERVICE INTERVALS

Simple servicing.

- 1** Grouped greasing points make regular maintenance easier and quicker.
- 2** Standard refuelling pump with and without in-line fuel filter to protect the pump and engine.
- 3** Ground level access to hour meter, HVAC filter, cab air filter and single fuse box. Optional LED convenience lighting for the service bay and upper structure.
- 4** Bolt-on handrails and mirrors for easy replacement if damaged.
- 5** 1,000 hour engine air filter life achieved using a standard fit system with Powercore Nanofilter technology.
- 6** Large single face cooling pack means more efficient cooling and easy access for cleaning.



EXCEEDINGLY SAFE

At JCB we take safety very seriously and we make sure this forms an important part of the design process. So whether you're an operator, service engineer or site worker, we make working safer.

Safer working.

- 1 The I31X boasts anti-slip surfaces and comfortable, well positioned grab handles and an area free of tread plate dimples to allow for kneeling during servicing.
- 2 Flattest, safest operator access to the top of the machine with built in kick strips around the edges.
- 3 Optional twin or 360° cameras helps operators operate safely.
- 4 Operator safety is paramount to JCB and the optional dipper limiter can be configured through the display to avoid a cab strike.



SPECIFICATION I31X

STATIC DIMENSIONS

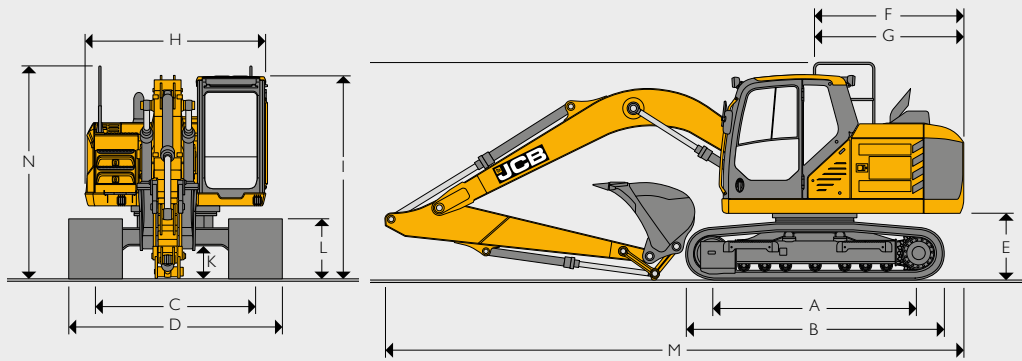

STATIC DIMENSIONS

Model		I31X LC			
A	Track length on ground	mm	2865		
B	Undercarriage overall length	mm	3590		
C	Track gauge	mm	1990		
D	Width over tracks (500 mm trackshoes)	mm	2490		
D	Width over tracks (600 mm trackshoes)	mm	2590		
D	Width over tracks (700 mm trackshoes)	mm	2690		
D	Width over tracks (850 mm trackshoes)	mm	2840		
E	Counterweight clearance	mm	905		
F	Tail length	mm	2103		
G	Tail swing radius	mm	2150		
H	Width of upper superstructure	mm	2490		
I	Height over cab	mm	2866		
I	Height over cab (vandal guard – optional)	mm	3172		
I	Height over cab (FOPS guard)	mm	2965		
J	Height over grab rail	mm	3002		
K	Ground clearance	mm	425		
L	Track height	mm	811		
		Mono			
Dipper lengths		2.5m	2.7m	3.0m	
M	Transport length	mm	7659	7654	7604
N	Transport height	mm	3002	3209	3289

ENGINE

Model	JCB Dieselmax 430 TCA EU Stage V Compliant
Type	4-stroke, 4-cylinder in-line, common rail, direct injection, turbocharged and intercooled diesel
Rated power	55kW (74 hp) at 2200rpm (ISO 14396)
Piston displacement	3.0 Litres
Air filtration	Dry element with secondary safety element and in cab warning indicator
Starting system	24 volt
Batteries	2 x 12 volt
Alternator	24V 100A
Maximum torque	400Nm
Bore and stroke	92mm & 112mm

SWING SYSTEM

Swing motor	Axial piston
Swing brake	Hydraulic braking plus automatic spring applied disc type parking brake
Swing torque	36.0 kNm
Swing speed	13.1 rpm
Swing gear	Large diameter, internally toothed fully sealed grease bath lubricated
Dipstick	Remote

TRACK DRIVE

Type	Fully hydrostatic, two speed with autoshift
Travel motors	Variable swash axial piston type, fully guarded within undercarriage frame
Final drive	Planetary reduction, bolt-on sprockets
Service brake	Hydraulic counter balance valve
Park brake	Disc type, spring applied, automatic hydraulic release
Gradeability	70% (35 deg) continuous
Travel speed	LC
	High – 6.6 km/h
	Low – 3.8 km/h
Tractive effort	116 kNm

HYDRAULIC SYSTEM

Pumps	
Main pumps	2 variable displacement axial piston type
Maximum flow	2 X 130 l/min
Servo pump	Gear type
Servo pump maximum flow	30 l/min

Control valve
A combined four and five spool control valve with auxiliary service spool as standard

Relief valve settings	
Boom/Arm/Bucket	314 bar
With power boost	343 bar
Swing circuit	279 bar
Travel circuit	343 bar
Pilot control	40 bar

Filtration	
In tank	105 micron, suction strainer
Main return line	10 micron, glass fibre element
Pilot drain line	10 micron, glass fibre element
Pilot line	10 micron, glass fibre element
Hydraulic hammer return	10 micron, reinforced microform element

Hydraulic cylinders			
	Quantity	Bore mm	Rod diameter mm
Boom	2	100	75
Arm	1	115	80
Bucket	1	95	70

SERVICE CAPACITIES

Fuel tank	Litres	260
Engine coolant	Litres	19.7
Engine oil	Litres	14
Swing reduction gear	Litres	2.2
Track reduction gear (each side)	Litres	3.5
Hydraulic system	Litres	126
Hydraulic tank	Litres	133

OPTIONAL BLADE

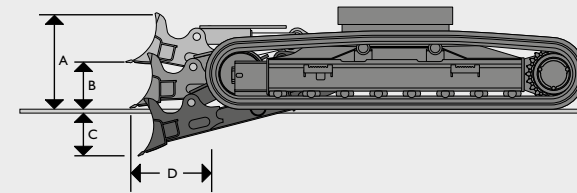

A	Blade height	mm	901
B	Blade lift above ground	mm	448
C	Blade cut below ground	mm	508
D	Blade forward of track	mm	412
	Dozer width – 500mm tracks	mm	2490
	Dozer width – 600mm tracks	mm	2610
	Dozer width – 700mm tracks	mm	2710

Additional machine weight with blade			
	500mm tracks	kg	806
	600mm tracks	kg	814
	700mm tracks	kg	821

SOUND LEVEL

Sound level in cab according to ISO 6396	67 dB LpA
External sound level according to ISO 6395 and EU Directive 2000/14/EC	99 dB LwA

SPECIFICATION I31X

UNDERCARRIAGE

Carriage options	LC – Long Carriage.			
Construction	Fully welded 'X' frame type with central bellyguarding and sloping sidemembers with dirt relief holes under top rollers.			
Recovery point	Front and rear.			
Track type	Sealed and lubricated.			
Upper and lower rollers	Heat treated, sealed and lubricated.			
Track adjustment	Grease cylinder type.			
Track idler	Sealed and lubricated, with spring cushioned recoil.			
Track shoe options	500mm	600mm	700mm	850mm
	•▲■	•■	•	•
No. of upper rollers (per side)	2			
No. of lower rollers (per side)	7			
No. of track guides (per side)	2 optional			
No. of track shoes (per side)	44			

- TRIPLE GROUSER ●
- GEOGRIP ▲
- RUBBER SHOES ■

WEIGHTS AND GROUND BEARING PRESSURES

Figures include standard 442kg bucket, operator, full fuel tank and 2.5m dipper.

		500mm shoes	600mm shoes	700mm shoes
I31 LC Monoboam				
Machine weight	kg	14388	14604	14819
Ground bearing pressure	kg/cm ²	0.50	0.42	0.37

BUCKET AND ARM COMBINATION

Bucket options	mm	GP Bucket								HD Bucket						Ditch Maintenance		HD Bucket					
		450	600	700	800	900	1000	1250	1350	458	610	762	915	991	1219	1524	1836	600	700	800	1000	1200	1300
Bucket width	mm	450	600	700	800	900	1000	1250	1350	458	610	762	915	991	1219	1524	1836	600	700	800	1000	1200	1300
Bucket capacity	m ³	0.21	0.35	0.42	0.50	0.54	0.66	0.81	0.89	0.20	0.26	0.34	0.43	0.50	0.61	0.65	0.79	0.35	0.42	0.50	0.66	0.81	0.89
Bucket weight	kg	307	342	366	401	425	460	506	542	275	310	357	402	424	493	475	535	336	364	402	455	520	547

I31X LC																							
2.5 m Quickhitch (No Quickhitch)	□ (□)	□ (□)	□ (□)	□ (□)	□ (□)	□ (□)	□ (□)	□ (■)	■ (●)	□ (□)	□ (□)	□ (□)	□ (□)	□ (□)	□ (□)	□ (□)	□ (■)	□ (□)	□ (□)	□ (□)	□ (□)	■ (■)	■ (●)
2.7 m Quickhitch (No Quickhitch)	□ (□)	□ (□)	□ (□)	□ (□)	□ (□)	□ (□)	□ (□)	■ (●)	■ (●)	□ (□)	□ (□)	□ (□)	□ (□)	□ (□)	□ (□)	□ (□)	■ (●)	□ (□)	□ (□)	□ (□)	□ (□)	■ (●)	■ (●)
3.0 m Quickhitch (No Quickhitch)	□ (□)	□ (□)	□ (□)	□ (□)	□ (□)	□ (□)	□ (■)	■ (●)	● (X)	□ (□)	□ (□)	□ (□)	□ (□)	□ (□)	□ (□)	□ (■)	■ (●)	□ (□)	□ (□)	□ (□)	□ (■)	■ (●)	● (X)
I31X LCD																							
2.5 m Quickhitch (No Quickhitch)	□ (□)	□ (□)	□ (□)	□ (□)	□ (□)	□ (□)	□ (■)	■ (■)	□ (□)	□ (□)	□ (□)	□ (□)	□ (□)	□ (□)	□ (□)	□ (□)	□ (■)	□ (□)	□ (□)	□ (□)	□ (□)	□ (■)	■ (●)
2.7 m Quickhitch (No Quickhitch)	□ (□)	□ (□)	□ (□)	□ (□)	□ (□)	□ (□)	□ (■)	■ (●)	□ (□)	□ (□)	□ (□)	□ (□)	□ (□)	□ (□)	□ (□)	□ (□)	□ (■)	□ (□)	□ (□)	□ (□)	□ (□)	□ (■)	■ (●)
3.0 m Quickhitch (No Quickhitch)	□ (□)	□ (□)	□ (□)	□ (□)	□ (□)	□ (□)	■ (●)	● (●)	□ (□)	□ (□)	□ (□)	□ (□)	□ (□)	□ (□)	□ (□)	□ (□)	■ (●)	□ (□)	□ (□)	□ (□)	□ (□)	■ (●)	● (●)

- = Suitable for general excavating materials up to 1800kg/m³.
- = Suitable for grading and loading materials up to 1500kg/m³.
- = Suitable for light excavating materials up to 1200kg/m³.
- X = Not recommended.

These recommendations are given as a guide based on typical operating conditions. Please contact your distributor for the correct selection of buckets and attachments to suit the application.

WORKING RANGE – MONOBOOM 4.7M

Dipper length:		2.5m	2.7m	3.0m	
A	Maximum digging reach	mm	8385	8564	8841
B	Maximum digging reach (on ground)	mm	8240	8422	8704
C	Maximum digging depth	mm	5564	5764	6063
D	Maximum digging height	mm	9164	9288	9503
E	Maximum dumping height	mm	6684	6806	7007
F	Maximum vertical wall cut depth	mm	5098	5295	5592
G	Minimum swing radius	mm	2212	2506	2575
H	Minimum dumping height	mm	2393	2267	1975
I	Maximum swing height	mm	6707	6833	7034
J	Minimum swing height	mm	3108	2922	2630
K	Bucket struck radius	mm	1248	1248	1248
L	Bucket rotation	degrees	182	182	182
	Maximum dipper tearout	Kgf	6587	6445	5986
	Maximum bucket tearout	Kgf	9432	9432	9432

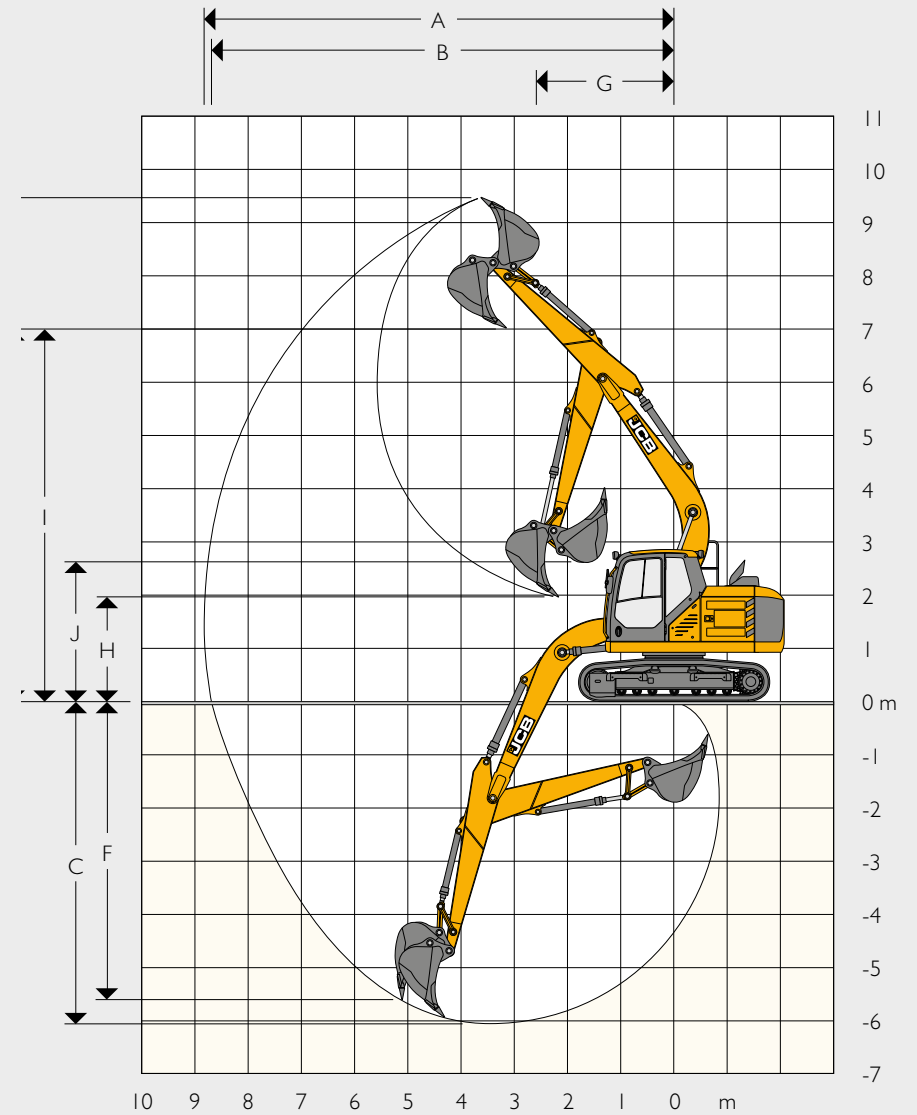











STANDARD/OPTIONAL EQUIPMENT











ENGINE		CAB & INTERIOR		HYDRAULIC SYSTEM	
JCB, Stage V compliant, water cooled diesel turbocharged after cooled electronic 4 cylinder 3 litre engine.	•	Sound-insulated and 4 dual shock mounted cab	•	Bucket regeneration	•
Start pre-heat	•	Opening front window and removable lower front window	•	One touch power boost	•
One touch idle	•	Upper door sliding glass in 2 directions	•	Cushion control	•
Auto-idle function	•	Upper windscreen wiper	•	Cylinder cushioning and contamination seals	•
Automatic engine shutdown	•	4 button joysticks	•	2 speed track motors	•
Fan guard	•	Travel pedals and T handle levers	•	Oil cooler	•
Heavy duty batteries	•	2 foot rests	•	I0 attachment settings through the display	•
Fuel filter with sedimenter	•	Immobiliser	+	High, merged, medium and low flow options (shut off taps as standard)	+
Electronic engine control	•	Loudspeakers and connection for radio	•	Advanced tool select to control flow and pressure	+
Fuel cooler	•	Standard cab filtration	•	Proportional control joystick sliders with electronic foot pedal	+
Refuelling pump	•	Electric dual tone horn	•	Bio oil	+
Additional fuel filter with water separator	•	Interior cab light	•	Panolin oil	+
Reversing fan	+	3 x 12v sockets	•	Quickhitch pipework	+
		7" colour monitor	•	Hydraulic quickhitch	+
		Retractable 2" seatbelt	•	ISO/SAE change over	+
		Fixed roof glass	•	SAE to BSP converters on high flow auxiliary pipework	+
		Roof blind	•	Quick release couplings	+
		Cool box	•	Hose burst check valves (Boom, Arm)	+
		Cup holder	•	Twin HBCV For bucket cylinder	+
		Climate Control	•	Auxiliary vent to tank	+
		Rear window blind	•	Attachment case drain	+
		3" seat belt	+		
		2" hi vis seat belt	+	DIG END	
		3" hi vis seat belt	+	Grouped greasing	•
		Front blind	•	Auto greasing	+
		Side window blind	•	Dippers 2.5m, 2.7m, 3.0m	+
		Bluetooth radio (Linked to pod controls and screen)	•	HD dipper 2.5m, 3.0m	+
		Carbon air filter	+	Lifting hook tipping link	+
		Deluxe seat: Heated, adjustable air suspension seat with adjustable headrest.	•	Lifting shackle tipping link	+
		Super deluxe seat: Heated and air ventilation, adjustable air suspension seat with adjustable head rest and electric lumbar support	+	Bucket ram guard	+
		Rain guard visor	+	Guards for boom mounted lights	+
		Dual front wiper	+		
				OTHER	
		UNDERCARRIAGE		Ground level visible hour meter	•
		Greased and sealed track links	•	Large toolbox	•
		Twin track guards	+	Livelink telematics	•
		600, 700, 800, 850mm triple grouser shoe	+	Wide core radiators	+
		500, 600, 700 dozer	+	HD slew bearing seal	+
				10mm heavy duty plates for upper and lower structure	+
				Flyscreen (Cooling Pack + Condenser)	+
				Guards for work lights	+
				Service bay & access lighting	+
				GPS systems	+

STANDARD •
OPTIONAL +











LIFT CAPACITIES – DIPPER LENGTH: 2.5M, MONOBOOM: 4.7M, TRACKSHOES: 500MM, NO BUCKET **I31X LC MONO**

Reach	3m		4m		5m		6m		Capacity at Max. Reach		
											
Load Point Height	kg	kg	kg	kg	kg	kg	kg	kg	kg	kg	mm
6m			2776*	2776*	2975*	2975*			2230*	2230*	5539
4.5m			3173*	3173*	3086*	3086*	3071*	2520	2065*	2065*	6484
3m	5341*	5341*	4192*	4192*	3628*	3218	3322*	2441	2049*	1912	6984
1.5m	7036*	6272	5387*	4138	4306*	3022	3194	2332	2147*	1802	7137
0m	6455*	5975	5286	3914	4145	2877	3453	2243	2383*	1829	6965
- 1.5m	8294*	5946	5366	3844	4238	2819	3454	2213	2865*	2024	6442
- 3m	7287*	6056	5598*	3898	3757	2866			3251	2564	5468

LIFT CAPACITIES – DIPPER LENGTH: 2.7M, MONOBOOM: 4.7M, TRACKSHOES: 500MM, NO BUCKET **I31X LC MONO**

Reach	3m		4m		5m		6m		Capacity at Max. Reach		
											
Load Point Height	kg	kg	kg	kg	kg	kg	kg	kg	kg	kg	mm
6m					2779*	2779*			2329*	2329*	5770
4.5m			2959*	2959*	2926*	2926*	2924*	2528	2173*	2095	6680
3m	4964*	4964*	3979*	3979*	3479*	3226	3202*	2440	2164*	1828	7167
1.5m	7347*	6316	5205*	4148	4180*	3020	3110	2324	2267*	1724	7316
0m	6618*	5950	5195	3897	4072	2860	3397	2226	2510*	1745	7148
- 1.5m	8335*	5890	5353	3808	4220	2790	3452	2184	2581	1918	6640
- 3m	7459*	5984	5698*	3848	3850	2821			3164	2390	5700

LIFT CAPACITIES – DIPPER LENGTH: 3.0M, MONOBOOM: 4.7M, TRACKSHOES: 500MM, NO BUCKET **I31X LC MONO**



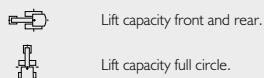







Reach	3m		4m		5m		6m		Capacity at Max. Reach		
											
Load Point Height	kg	kg	kg	kg	kg	kg	kg	kg	kg	kg	mm
6m					2515*	2515*	2376*	2376*	2038*	2038*	6121
4.5m			2650*	2650*	2701*	2701*	2728*	2555	1913*	1913*	6985
3m	4421*	4421*	3673*	3673*	3271*	3259	3038*	2458	1907*	1719	7451
1.5m	6885*	6425	4945*	4193	4005*	3040	2995	2331	1995*	1624	7594
0m	7085*	5961	5876*	3904	3974	2861	3322	2221	2196*	1639	7434
- 1.5m	8386*	5847	5336	3785	4196	2770	3447	2163	2232	1785	6947
- 3m	7705*	5912	5033	3800	3963	2780	3089	2196	2968	2173	6055













Notes:

1. Lifting capacities are based on ISO 10567, that is: 75% of minimum tipping load or 87% of hydraulic lift capacity, whichever is the less. Lifting capacities marked* are based on hydraulic capacity.
2. Lift capacities assume that the machine is on firm, level ground.
3. Lift capacities may be limited by local regulations. Please refer to your dealer.











LIFT CAPACITIES – DIPPER LENGTH: 2.5M, MONOBOOM: 4.7M, TRACKSHOES: 500MM, NO BUCKET **I3IX LCD MONO**

Reach	3m		4m		5m		6m		Capacity at Max. Reach		
											
Load Point Height	kg	kg	kg	kg	kg	kg	kg	kg	kg	kg	mm
6m			2776*	2776*	2975*	2975*			2230*	2230*	5539
4.5m			3173*	3173*	3086*	3086*	3071*	2647	2065*	2065*	6484
3m	5341*	5341*	4192*	4192*	3628*	3377	3322*	2568	2049*	2018	6984
1.5m	7036*	6597	5387*	4352	4306*	3182	3194	2458	2147*	1906	7137
0m	6455*	6299	5286	4126	4145	3037	3453	2371	2383*	1936	6965
- 1.5m	8294*	6270	5366	4058	4238	2978	3454	2340	2865*	2141	6442
- 3m	7287*	6380	5598*	4112	3757	3026			3251	2706	5468

LIFT CAPACITIES – DIPPER LENGTH: 2.7M, MONOBOOM: 4.7M, TRACKSHOES: 500MM, NO BUCKET **I3IX LCD MONO**

Reach	3m		4m		5m		6m		Capacity at Max. Reach		
											
Load Point Height	kg	kg	kg	kg	kg	kg	kg	kg	kg	kg	mm
6m					2779*	2779*			2329*	2329*	5770
4.5m			2959*	2959*	2926*	2926*	2924*	2655	2173*	2173*	6680
3m	4964*	4964*	3979*	3979*	3479*	3386	3202*	2568	2164*	1930	7167
1.5m	7347*	6640	5205*	4362	4180*	3179	3110	2450	2267*	1824	7316
0m	6618*	6274	5195	4111	4072	3020	3397	2353	2164	1848	7148
- 1.5m	8335*	6214	5353	4022	4220	2950	3452	2312	2581	2031	6640
- 3m	7459*	6308	5698*	4061	3850	2980			3164	2524	5700

LIFT CAPACITIES – DIPPER LENGTH: 3.0M, MONOBOOM: 4.7M, TRACKSHOES: 500MM, NO BUCKET **I3IX LCD MONO**

Reach	3m		4m		5m		6m		Capacity at Max. Reach		
											
Load Point Height	kg	kg	kg	kg	kg	kg	kg	kg	kg	kg	mm
6m					2515*	2515*	2376*	2376*	2038*	2038*	6121
4.5m			2650*	2650*	2701*	2701*	2728*	2682	1913*	1913*	6985
3m	4421*	4421*	3673*	3673*	3271*	3271*	3038*	2585	1907*	1817	7451
1.5m	6885*	6749	4945*	4407	4005*	3199	2995	2458	1995*	1720	7594
0m	7085*	6285	5066	4118	3974	3020	3322	2348	2196*	1737	7434
- 1.5m	8386*	6171	5336	3999	4196	2930	3447	2290	2232	1892	6947
- 3m	7705*	6236	5033	4014	3963	2938	3089	2323	2968	2299	6055



Lift capacity front and rear.



Lift capacity full circle.

Notes:

1. Lifting capacities are based on ISO 10567, that is: 75% of minimum tipping load or 87% of hydraulic lift capacity, whichever is the less. Lifting capacities marked* are based on hydraulic capacity.
2. Lift capacities assume that the machine is on firm, level ground.
3. Lift capacities may be limited by local regulations. Please refer to your dealer.







Your nearest JCB dealer

9999/6156 en-GB 07/20 Issue 1 (Stage V)

JCB Sales Limited, Rocester, Staffordshire, United Kingdom ST14 5JP

Tel: +44 (0)1889 590312 Email: salesinfo@jcb.com

Download the very latest information on this product range at: www.jcb.com

©2015 JCB Sales. All rights reserved. No part of this publication may be reproduced, stored in a retrieval system, or transmitted in any form or by any other means, electronic, mechanical, photocopying or otherwise, without prior permission from JCB Sales. All references in this publication to operating weights, sizes, capacities and other performance measurements are provided for guidance only and may vary dependant upon the exact specification of machine. They should not therefore be relied upon in relation to suitability for a particular application. Guidance and advice should always be sought from your JCB Dealer. JCB reserves the right to change specifications without notice. Illustrations and specifications shown may include optional equipment and accessories. The JCB logo is a registered trademark of J C Bamford Excavators Ltd.

